

## DOCUMENT RESUME

ED 234 806

IR 050 438

AUTHOR Moss, Charles A., Jr.  
 TITLE Planning Barrier Free Libraries. A Guide for Renovation and Construction of Libraries Serving Blind and Physically Handicapped Readers.  
 INSTITUTION Library of Congress, Washington, D.C. National Library Service for the Blind and Physically Handicapped.  
 REPORT NO ISBN-0-8444-0352-0  
 PUB DATE 81  
 NOTE 67p.  
 PUB TYPE Guides - General (050) -- Audiovisual Materials (100) -- Tests/Evaluation Instruments (160)

EDRS PRICE MF01/PC03 Plus Postage.  
 DESCRIPTORS \*Accessibility (for Disabled); Architectural Programing; \*Building Design; Check Lists; Construction Programs; \*Design Requirements; Diagrams; Facility Improvement; Guidelines; Interior Design; \*Library Facilities; \*Physical Disabilities; \*Visual Impairments  
 IDENTIFIERS \*National Library Service for the Blind

## ABSTRACT

Guidelines and sample designs for the construction or renovation of libraries providing services to blind and handicapped individuals are introduced by brief discussions of the responsibilities of members of the planning team, planning prerequisites, funding, and architect and site selection. Barrier-free designs are then suggested for the entry and lobby; passenger elevator, reading and study areas, conference or meeting rooms, restrooms, administrative offices, staff lounge, bookstacks, shipping and receiving areas, work area, freight elevator, storage room, computer room, machine repair room, machine storage room, and audiobook production center. These descriptions include: floor plans or drawings; factors to be considered in planning, such as space requirements, number of patrons to be served, and staff needs; and types of furniture and equipment appropriate for the area. A review of the role of the architect through each phase of the project includes drawings and suggestions for meeting the specific needs of patrons with visual impairments or in wheelchairs. A final section discusses the renovation of existing buildings to provide barrier-free access. Appendices present data on minimum space and personnel requirements for such libraries, diagrams showing additional restroom requirements, a flow diagram for the library, a suggested revised accessibility check list, and diagrams showing the approximate time schedules for both new construction and building renovation. (ESR)

\*\*\*\*\*  
 \* Reproductions supplied by EDRS are the best that can be made \*  
 \* from the original document. \*  
 \*\*\*\*\*

# Planning Barrier Free Libraries

U.S. DEPARTMENT OF EDUCATION  
NATIONAL INSTITUTE OF EDUCATION  
EDUCATIONAL RESOURCES INFORMATION  
CENTER (ERIC)

- This document has been reproduced exactly as received from the person or organization originating it.
- Minor changes have been made to improve reproduction quality.
- Points of view or opinions stated do not necessarily represent official ERIC position or policy.

**A Guide for Renovation and Construction of Libraries  
Serving Blind and Physically Handicapped Readers**

ED234806

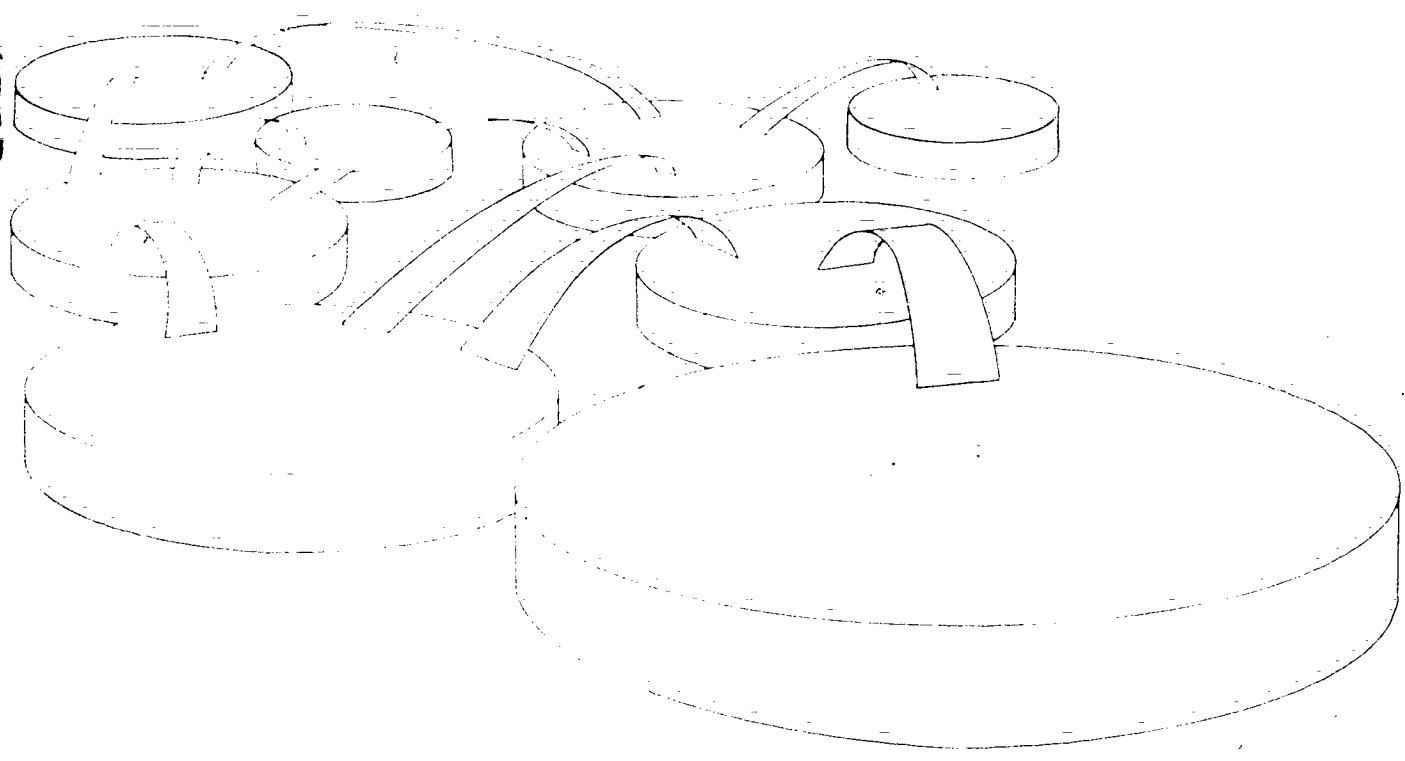

FR 050 438

**National Library Service  
for the Blind and  
Physically Handicapped  
The Library of Congress  
Washington 1981.**

This guide was prepared for the National Library Service for the Blind and Physically Handicapped by Charles A. Moss, Jr., of Moss, Garikes & Associates Architects, Inc. Birmingham, Alabama, in consultation with Ms. Miriam M. Pace, Regional Librarian, Alabama Regional Library for the Blind and Physically Handicapped. Illustrations by Rick Davidson.

Cataloging in publication data

National Library Service for the Blind and  
Physically Handicapped.  
Planning Barrier-Free Libraries.

1. Library architecture and the physically  
handicapped. 2. Library planning. I. Title.  
Z711.92.P5N39 1981 027.6'63 80-607821  
ISBN 0-8444-0352-0

# Contents

<i>I. Introduction</i> .....	1
A. Purpose .....	1
B. Planning Team .....	2
<i>II. Functional Program</i> .....	4
A. Planning Prerequisites .....	4
B. Selecting the Architect .....	4
C. Funding .....	5
D. Planning Program .....	6
E. Site Selection .....	23
<i>III. Architectural Program</i> .....	25
A. Programming .....	25
B. Schematic Design .....	25
C. Design Development .....	28
D. Working with Consultants .....	28
E. Preliminary Drawings .....	29
F. Barrier-Free Design .....	30
G. Contract Documents .....	33
H. Approving Agencies .....	34
I. Bidding and Negotiation .....	34
J. Construction .....	35
K. Summary .....	36

IV. Renovations .....	37
A. Site Suitability .....	37
B. Analysis of Existing Services .....	40
C. Barrier-Free Design .....	42
D. Summary .....	42
V. Appendices .....	43
A. Minimum Space and Personnel Required .....	43
B. Other Restroom Requirements .....	44
C. Flow Diagram .....	47
D. Suggested Revised Accessibility Checklist .....	50
E. Approximate Time Schedule for New Network Library Construction .....	57
F. Approximate Time Schedule for Renovation of Building for Network Library .....	60

# ***I / Introduction***

The design and construction of a functional, barrier-free library for blind and physically handicapped individuals is a challenging opportunity, unique to our specific field of library service. But librarians know program goals—not architecture—and there are virtually no guidelines for either planning or construction of buildings to meet our needs or those of our patrons. Libraries designed specifically for our clientele are a relatively new concept, inappropriate to the “warehouse” environment, with small staff work space, historically considered sufficient.

## **A. Purpose**

This guide, therefore, suggests how to establish a new building or renovation program for a network library. Construction of an “ideal” library is discussed, but the size of the building is obviously determined by the population to be served, the size of the staff, and the funds available. Space requirements, various types of equipment, and types of furniture and equipment are recommended. The American Library Association’s (ALA) *Standards of Service for the Library of Congress Network of Libraries for the Blind and Physically Handicapped* must be considered. The National Library Service for the Blind and Physically Handicapped (NLS) is available also for consultation and assistance. It is not always possible, of course, to construct a new building, so this guide also discusses how to examine and analyze an existing structure with an eye toward renovation.

## **B. Planning Team**

The planning team may have many members, but two, besides the architect, must set the tone and character for the building. The agency director is usually responsible to a governing board to fulfill its policies and implement the building program as expeditiously as possible. The network librarian, as a consultant, provides the technical knowledge to fulfill the desires of the board. These three, the director, the network librarian, and the architect, form the nucleus of the planning team that must begin the project, organize it, analyze it, and thoughtfully carry it into the building program.

### ***Architect's Responsibility***

An architect should be consulted during the initial planning stages. Architectural expertise, sensitivity to space and analysis of its use, together with professional knowledge of materials and construction, will help you develop a building program and carry it forward to a finished library. The architect is a valuable member of the planning team; select that person carefully.

### ***Director's Responsibility***

The director of the agency that supervises the network library is directly responsible for constructing or renovating a library. The director is the most likely person to initiate the project, perhaps as a reaction to a suggestion from the administrative agency, from the more vocal members of the handicapped community, or from the network librarian.

The director must either originate or direct the funding effort to finance the work. The agency budget may need to be increased to employ additional library staff, or to purchase new equipment and furnishings.

The director must be influential in selecting the architect, within the restraints imposed by the governing body or the regulations of the funding source. The director must report the progress of the project to the governing body at regular intervals, seeking the board's approval and sustaining its interest.

### ***Network Librarian's Responsibility***

The network librarian should be a pivotal member of the building or renovation team. A 5-year plan or long-range program for the network library, usually written by the librarian, records the goals to be achieved, as

well as the objectives and tasks to be performed to reach those goals. In addition, the librarian's thorough knowledge of the area and patrons served, of the number and job descriptions of staff members, of the procedures and policies of NLS, and of other organizations working with blind and physically handicapped individuals place the librarian in a unique position to serve as project coordinator. If not the project coordinator, the librarian must be a vocal and insistent member of the team to secure a functional building capable of providing patrons the services they require at minimal cost and maximal efficiency and productivity.

### *Other Planning Team Members*

As stated, the nucleus of the planning team is the director, the librarian, and the architect. A blind or physically handicapped patron should also be a part of the planning team and the administrative agency may wish to include others: an additional technical staff member or a civic leader. The team, however, should not be too large; it is usually more efficient for a small, representative committee to consider the many issues and make decisions. The planning team should always discuss its assessment of the project and reasons for decisions with the administrative agency.

The planning team should also consult with a consumer advisory council. If one is not appointed, survey blind and physically handicapped patrons for their views and needs on architectural features of the new facility. Brief the council periodically during design development and construction.



## ***II / Functional Program***

### **A. Planning Prerequisites**

A decision by the administrative agency to build a new or to renovate an existing building for a network library should be made on the basis of a positive feasibility study or as implementation of a long-range plan. Then begins the process of selecting a planning team and an architect, locating funding sources, planning the program and other steps essential to preparing and executing the building program, and selecting the site.

### **B. Selecting the Architect**

Select an architect with knowledge and expertise in library design as soon as possible in the planning process. An architect offers valuable services converting the functional program of the planning team into a completed library building.

There are several ways to select an architect. Consult community leaders for recommendations of architects with whom they are familiar and who have expertise in libraries. Obtain names of architects from the American Institute of Architects, either locally or nationally. This organization usually has a list of architects interested in designing libraries or barrier-free buildings.

After compiling a list, arrange interviews with the principals of each firm being considered so that the planning team can explain the functional program. If the firms are interested and available, ask them to furnish the following:

- A brief history of the firm and its organizational make-up;
- A list of completed projects and the name of a person who can be contacted regarding each project, as well as a list of the firm's present and proposed projects;
- The name of a person or persons in the architect's office with whom your project coordinator will deal;
- The total number of professional members of the firm—registered architects, engineers, and so on. If the engineers are staff members, their curriculum vitae should be in the firm's brochure. If the firm uses consulting engineers, biographical sketches should be available.
- A description of the firm's fee schedules and provision for payment;
- A selection of photographs of completed work; and
- A listing of any special qualifications the firm has for designing libraries.

After collecting this information, contact the references provided.

Consider making field trips to several sites of work completed by each firm.

In evaluating the firms, review the services each offers to determine if the same services will be rendered for the fee requested. The architect must carry out the client's wishes and perform the services promised.

Selecting the architect is time consuming, but you must choose the firm best suited to your project before you enter into any agreement between owner (administrative agency) and architect.

## C. Funding

The library's program depends on one factor—money. Funding is the obvious first step in the planning process and determines the amount of construction or renovation possible. Contact NLS for information about program grants or special funds. Legislation that is supported by consumer groups may result in state funding. Locally, funds are often secured through donations and through the help of a Friends of the Library group.

The budget for the library building itself, discussed in more detail under the Architectural Program (Chapter III), is *only one part* of the project

budget. Money for furnishings, equipment, fees, and contingencies is also part of the architectural program. In the planning process, a budget must be established by the planning team, revised by the architect, and approved by the administrative agency. *The agency director and librarian must plan a realistic operating budget for the new building including staff, supplies, and maintenance.* Future income sources must also be identified that will enable the network library to fulfill long-range planning goals and increase the quality of services to patrons.

#### **D. Planning Program**

The planning team must meet, review, and analyze space for the program areas. The spaces must be barrier-free not only for patrons, but also for employees; thus all areas of the library must be planned with sensitivity. Public areas for patrons, their families, and friends, as well as for space to display and explain special library materials and services, must be of adequate size (note Minimum Space and Personnel Required, Appendix A).

Staff requirements for the new facility are determined by the number of patrons to be served; planning should include staff projections for patron growth. Even though there are many variables, a typical staff might consist of the head librarian, one or more reader advisors, a volunteer coordinator, a program coordinator, two or more clerk-typists-secretaries, two or more audio technicians, and two or more warehouse persons. Consult the *Standards of Service for the Library of Congress Network of Libraries for the Blind and Physically Handicapped*, American Library Association, before finalizing staff plans for your particular library.

Program areas are described generally here to help the planning team establish a dialog. The final space allocations must be determined with the architect and will depend on the number of patrons to be served. Note, however, Appendix A which lists minimum space requirements for a library serving less than 10,000 patrons. No exact size can possibly apply to all network libraries.

Each network library must determine the number of "walk-in" patrons expected, the teaching programs to be employed, the funds allocated, the size of the property for the new building, and the area for an addition or the space available for a renovated library. Again, the planning team must work together to decide on requirements for the types of space described in the following pages, relying heavily on the architect's knowledge of space sizes, assignments, and utilization.

## Entry and Lobby

The lobby or waiting areas should be large enough for wheelchairs to move freely from the lobby to all other areas. Eliminate sharp corners and protruding furniture legs by rounding the walls and selecting furnishings carefully.

Place a receptionist as near the entry as possible. Conveniences near the entry (such as a pre-dialed phone or a tactile map of the building) contribute to the independence of the patrons (Figure 1).

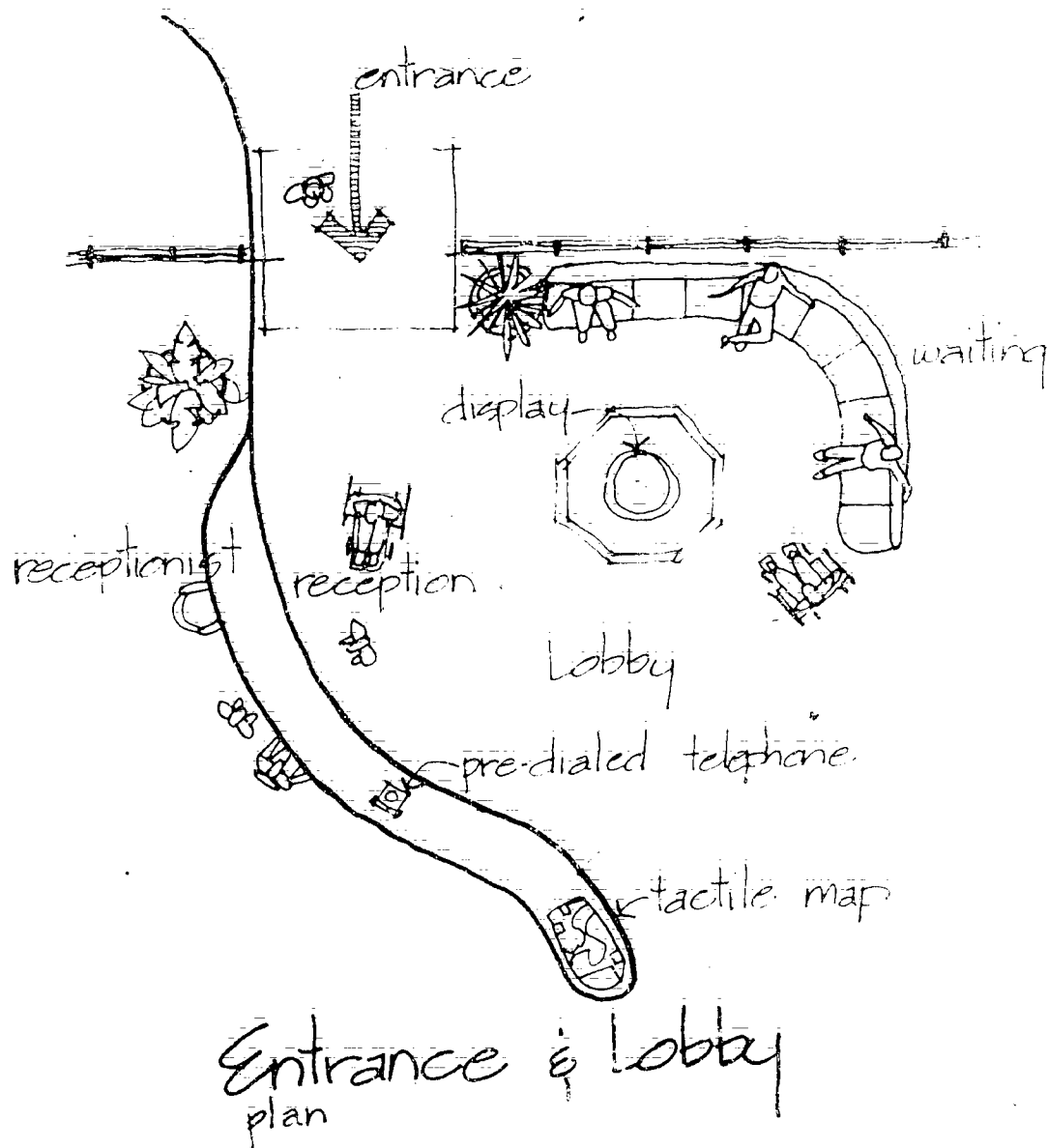
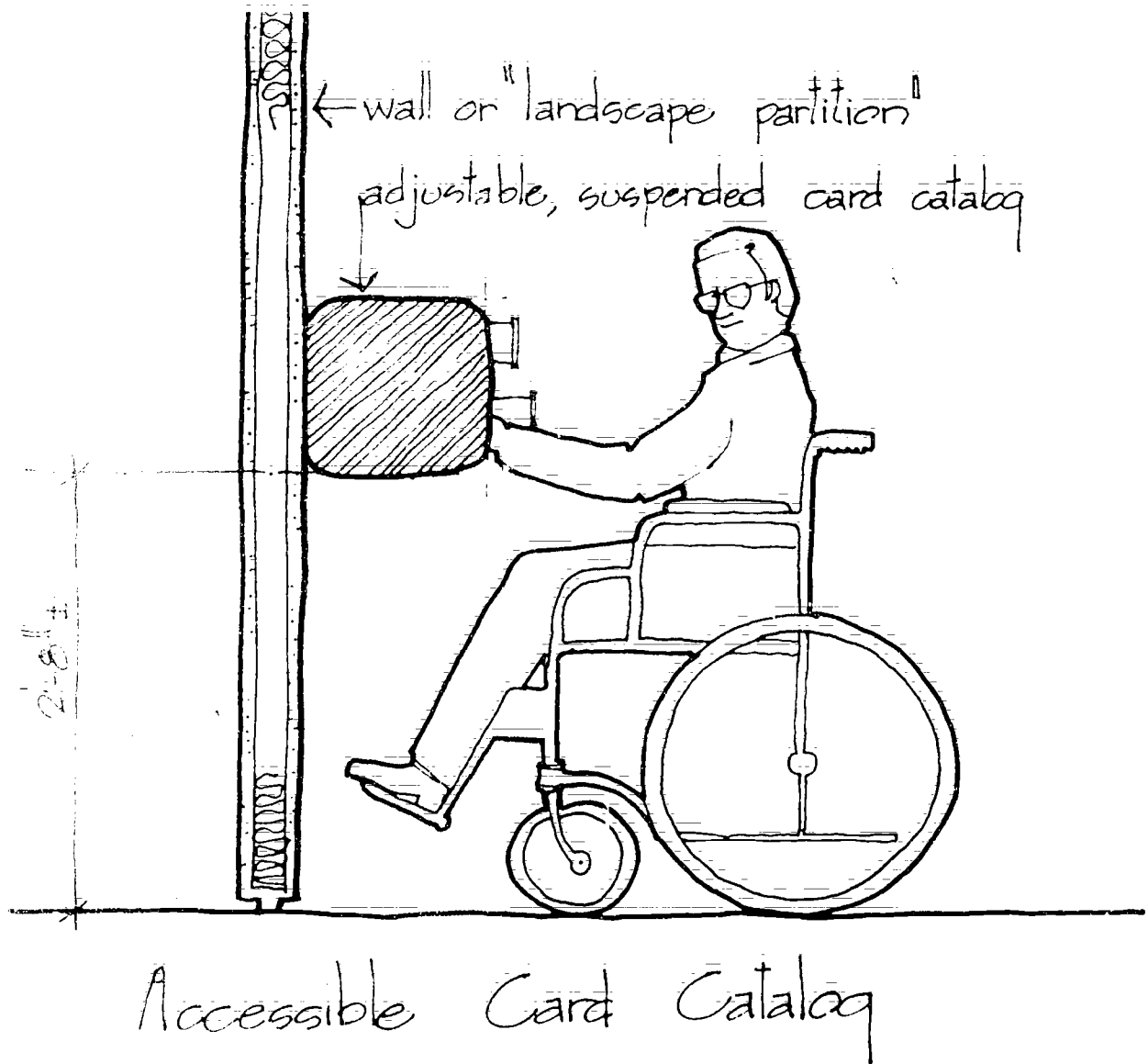

Figure 1

## Passenger Elevator

Elevators for patrons can employ several conveniences. Call buttons, with braille identification and raised numerals, should be at convenient heights for wheelchair users. Use audible, as well as visible signals to indicate the location of the elevator. The elevator cab entrance must be wide enough to accommodate a motorized wheelchair, and the cab itself must be large enough for this type of wheelchair and at least one other person. Inside the cab, place the controls and an emergency telephone low enough for the wheelchair user to reach easily. These items must also carry braille identification.



8 Figure 2

### ***Reading and Study Areas***

Adjacent to and easily accessible from the lobby should be the patron area for reading, studying, and learning how to use new and unusual aids. Even though the number of blind and physically handicapped patrons who use this area may be small, the area should be large enough for several tables and chairs, adjustable shelves for current books and periodicals, and a display area. You can provide tables or counters for study and for aids; carrels suspended from wall tracks or partitions have also proved satisfactory. Study carrels can be wired for electrical outlets to accommodate playback equipment, optacons, and apollo lasers. Suspending these carrels eliminates protruding legs and braces.

A card or microfiche catalog may be placed nearby to give patrons access to a comprehensive index of library materials provided by NLS, the serving library, and others. The card catalog can be placed on a table or in a carrel, or suspended from the wall to allow free and easy access (Figure 2).

### ***Conference or Meeting Room***

A conference room serves many purposes. Purchase stackable chairs so they can be removed for total wheelchair patron use of the room. Provide a room large enough to accommodate groups of wheelchair patrons attending demonstrations and instructional workshops (Figure 3). Design an area in the

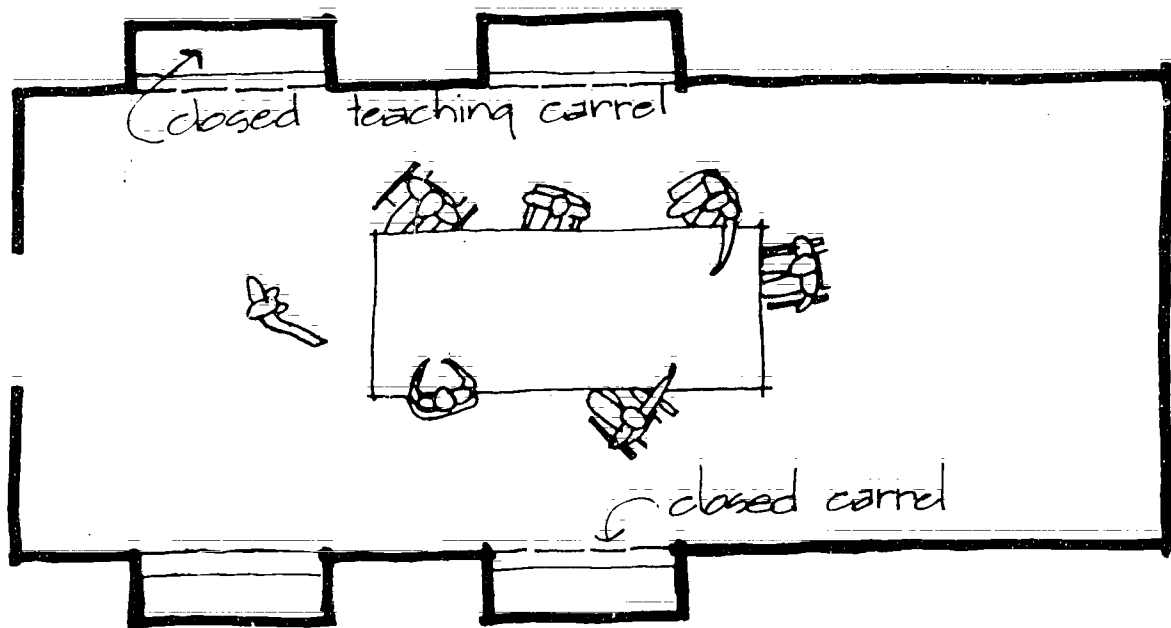
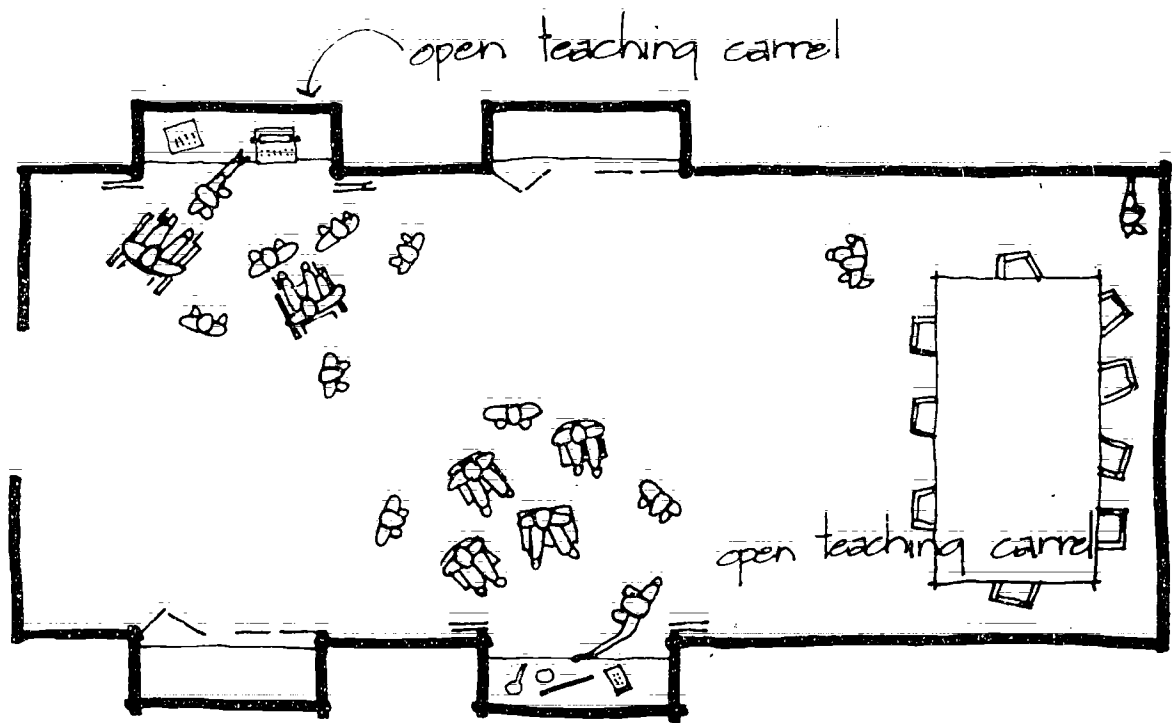

Figure 3

Conference/Meeting Room  
plan



## Conference/Meeting Room plan

Figure 4

room with adjustable counters or carrels for teaching programs—the use of adapted kitchen utensils, gardening clinics, and so on. Games, toys, braille writers, and typewriters, talking calculators, and other types of aids can be closeted or recessed in this room.

The conference room can be used for meetings of organizations of blind and physically handicapped individuals as well as for volunteers and other groups who work with your patrons. Here you can also provide inservice training for staff members and network librarians, and others working with the library's programs (Figure 4).

The room can also contain shelves for a core collection on blindness and physical handicaps, memorial books and braille and large print reference books for patron use.

## Restrooms

Restrooms convenient to the conference room should have automatic or regular sliding doors. Push plates at a height of 4'0" will allow handicapped users to open the door easily. An electric eye on the inside of the door will keep the door open as long as the beam is broken. Do not use mats and scans to open doors automatically unless restrooms are out of the main traffic pattern (Figure 5). For other restroom requirements, see Appendix B.

## Administrative Offices

Administrative offices should include a private office for the head librarian. The office should be of sufficient size to accommodate a desk, credenza-file, shelf storage, and two or three armchairs. If no conference room is planned, include a small table to accommodate 6 or 8 persons.

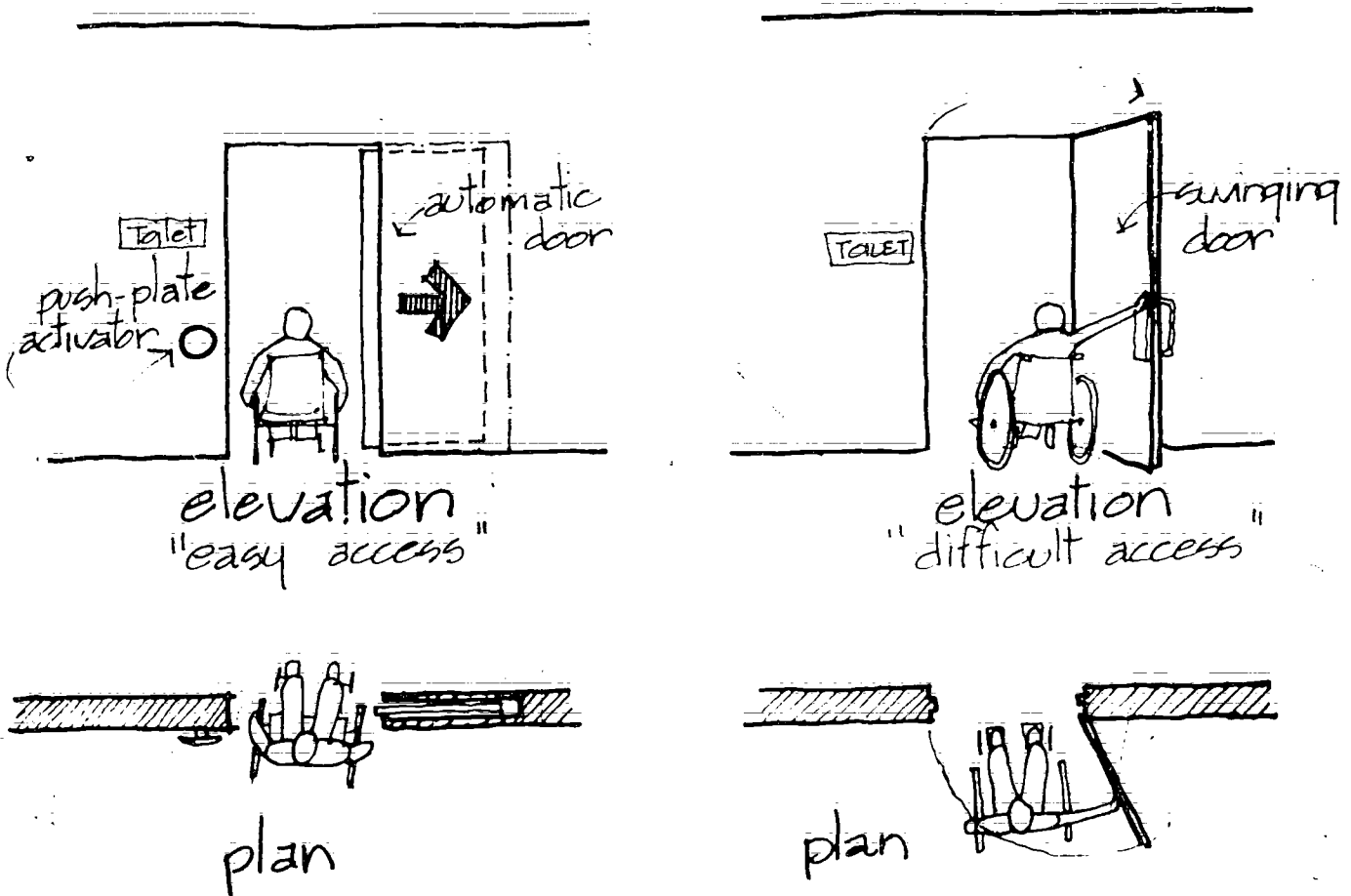
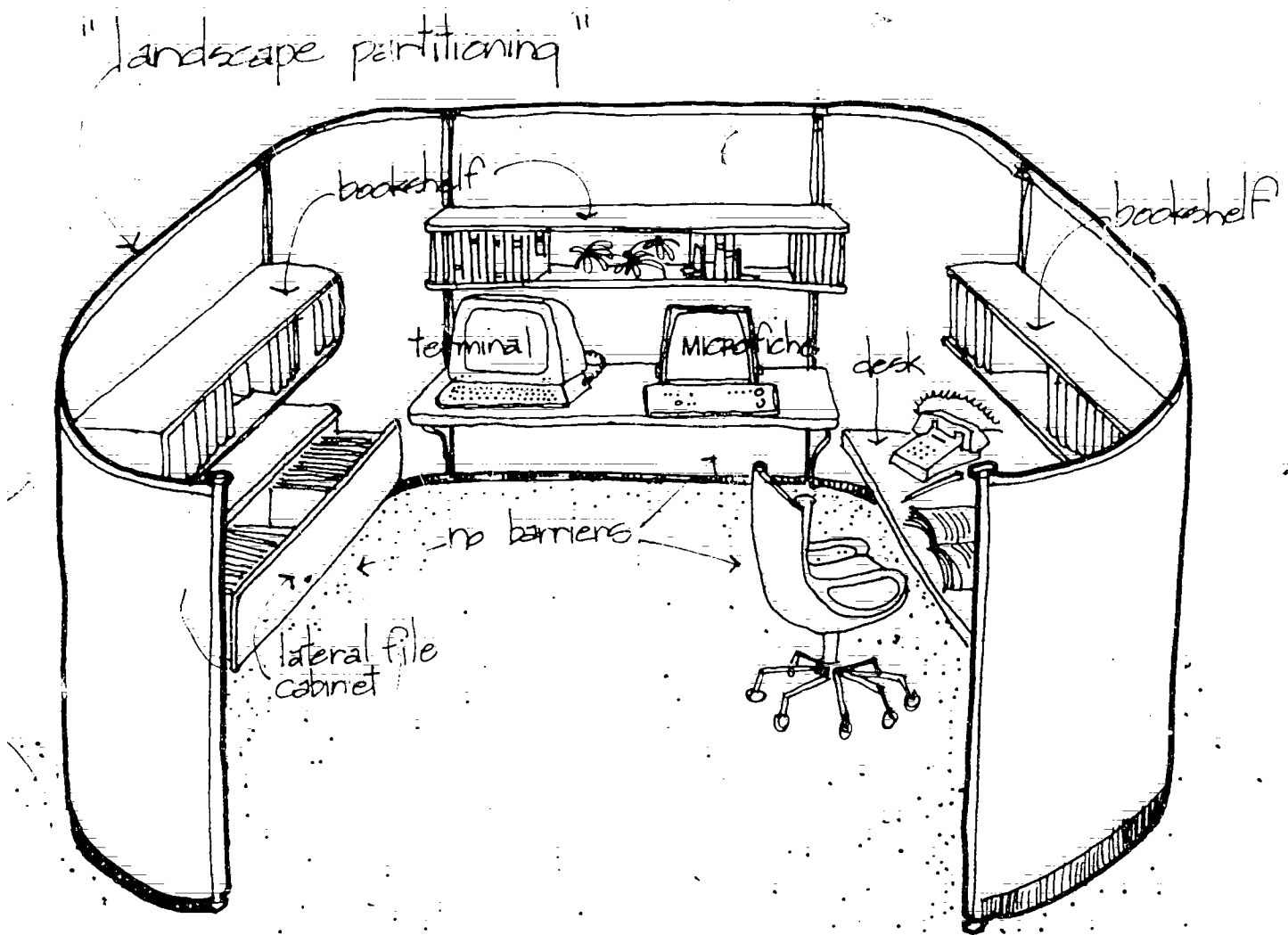

Figure 5





**Figure 6**

Some library programs allow for additional offices or spaces for the assistant librarian, business manager, and others. Note Appendix A and refer to the *Standards of Service for the Library of Congress Network of Libraries for the Blind and Physically Handicapped*.

Reader advisors may all be located in one space, if these personnel are separated by low walls, files, or enough room to allow privacy. Much of the reader advisor's time is spent on the telephone; therefore, quiet, private areas are essential. Provide space for a microfiche machine, and, perhaps, for the later addition of computer terminals.

Landscape partitions are readily available and provide flexibility by allowing for expansion and modification; they also provide a high degree of acoustic control. Rounded landscape partitions provide a barrier-free environment (Figure 6).

The volunteer and program coordinators can both be housed in the same area but, again, separate them with low walls or landscape partitions (Figure 7).

The clerk typists-secretaries need to be accessible both to the administrative offices and warehouse as they handle paperwork directly related to operating the library. Thus, these personnel must have space for files near their work area.

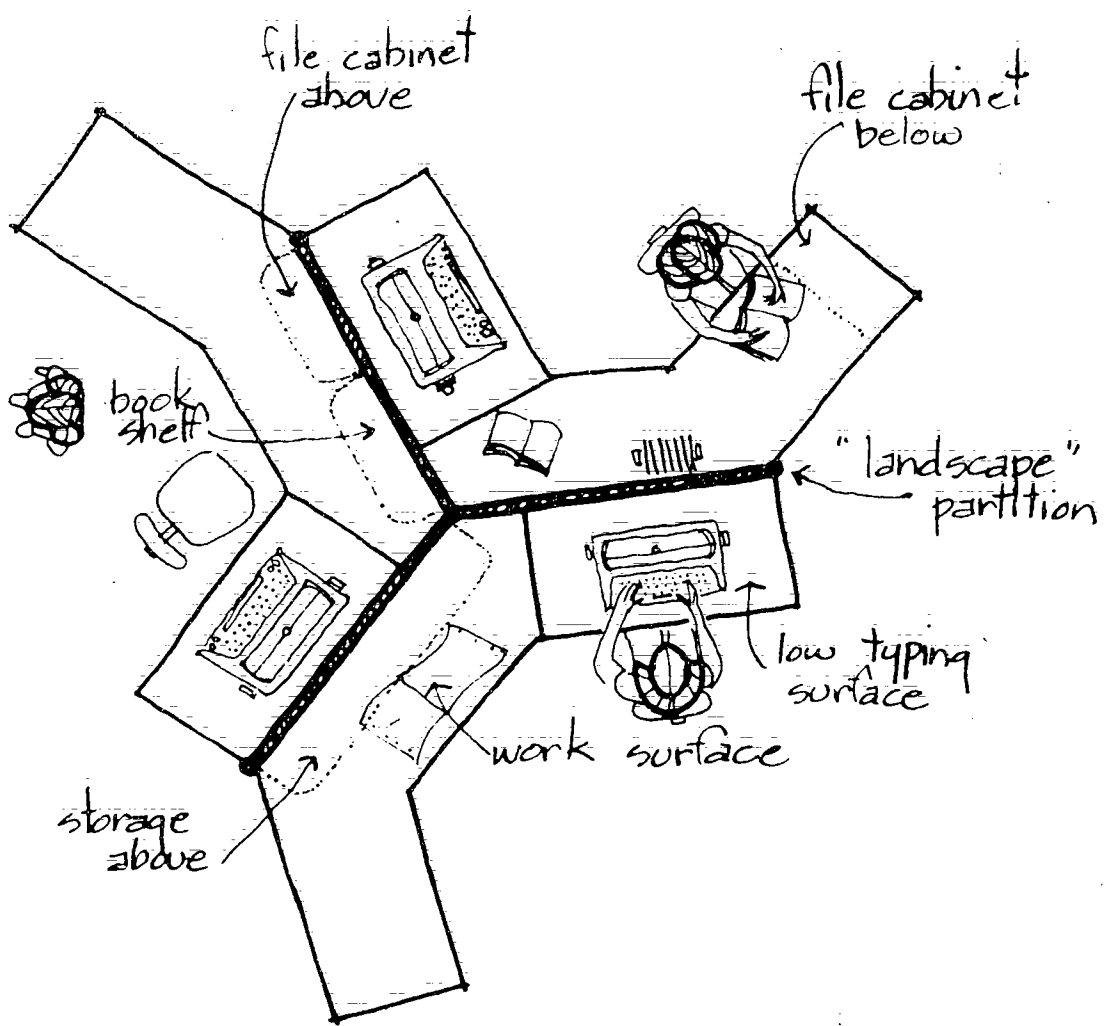

Figure 7

Essentially, there are two types of filing systems:

- Vertical files and
- Lateral files.

Lateral files can be suspended from landscape partitions and are more flexible than large floor-mounted vertical files. One lateral file drawer is comparable to one two-drawer vertical file cabinet. Also, some physically handicapped employees cannot reach the back of an open vertical file, but they do have total access to a lateral file.

### *Staff Lounge*

A lounge of sufficient size to serve the staff and volunteers should be included. Plan it large enough for wheelchair maneuverability. Include enough space for one or more tables and chairs for staff lunches and breaks. Include space for a rest area. Provide an area and outlets for food preparation equipment and vending machines.

### *Bookstacks*

The area for bookstacks will be the largest single area of the building. Stacks contain all the talking books, braille volumes, and a work area. The load-bearing capacity for all floors containing shelving must be designed to carry 150 to 170 pounds per square foot, live load. Refer to Section 4.1.5.1.2 (Table 4) of the ALA Standards as one guide for estimating the size of the stack area. Based on the experience of NLS and its four regional multistate centers, estimate and utilize shelving as follows (per standard library shelf of 3 linear feet):

<i>medium</i>	<i>volumes per shelf</i>	<i>shelf opening</i>
Braille (BR)	11-12	14 inches
Rigid Discs (TB, RD)	30 (if stored sideways)	12 inches
	27 (if stacked in 3 piles of 9 each)	12 inches
Recorded Cassettes (RC)	80 (if stacked in 5 piles of 8 each and placed 2 deep)	12 inches
	48 (if stored sideways and placed 2 deep)	7 inches

Multiply the number of containers per shelf times the number of shelves (6 for braille, 7 for talking books and cassettes, or 12 for cassettes shelved on edge) to derive the amount of shelving required.

Apply one of the formulas to determine how many linear feet of shelving are needed. Regional libraries must stock at least one copy of all recorded titles produced by NLS, plus multiple copies for its clientele, as well as its subregional libraries, if any. Also, space must be provided for future titles issued by NLS.

Braille volumes must be placed on shelves with 14 inches of clearance. A 3-foot shelf can accommodate up to 12 volumes, although the American Library Association standards call for 8 per shelf.

Double-faced shelving 24 inches deep is recommended. Aisle space depends on the volume of activity of the library. Keep aisles as narrow as possible to most effectively utilize available floor and cubic air space. Where book loan activity is light, aisles may be 27 inches. This size aisle is wide enough for book trucks. If aisles must be wide enough to accommodate mail tubs or wheelchairs, allow 40 inches per aisle.

Purchase shelving 90 inches (7.5 feet) high to derive maximum cubic space utilization.

Compact shelving can save space or time when employees are replacing the volumes on the shelves. Obviously, these shelves can contain more space in less area than does conventional shelving. Note the example in Figure 8 that 3 ranges of double-faced shelves required only 10 feet. In fact, 4 more 24-inch-wide shelves could be added to the compact shelving within 18 feet. Comparing Figures 8 and 9 show that within 18 feet are 3 ranges of standard double-faced shelves or 7 ranges of compact double-faced shelves.

Compact shelving moves on guides or tracks; the tracks must be left clear for the shelves to move freely. The shelves move either manually or electronically. To move a range manually requires only 30 pounds of pressure; the electronically operated controls require no manual effort.

Apply the same formula to determine the number of books per shelf for compact shelving as for standard shelving. If space is a major problem, the compact shelves certainly provide one answer. The high cost of compact shelving versus standard shelving, however, must be considered. Weigh also the cost per square foot of floor space, volume of book activity, and availability of space in general.

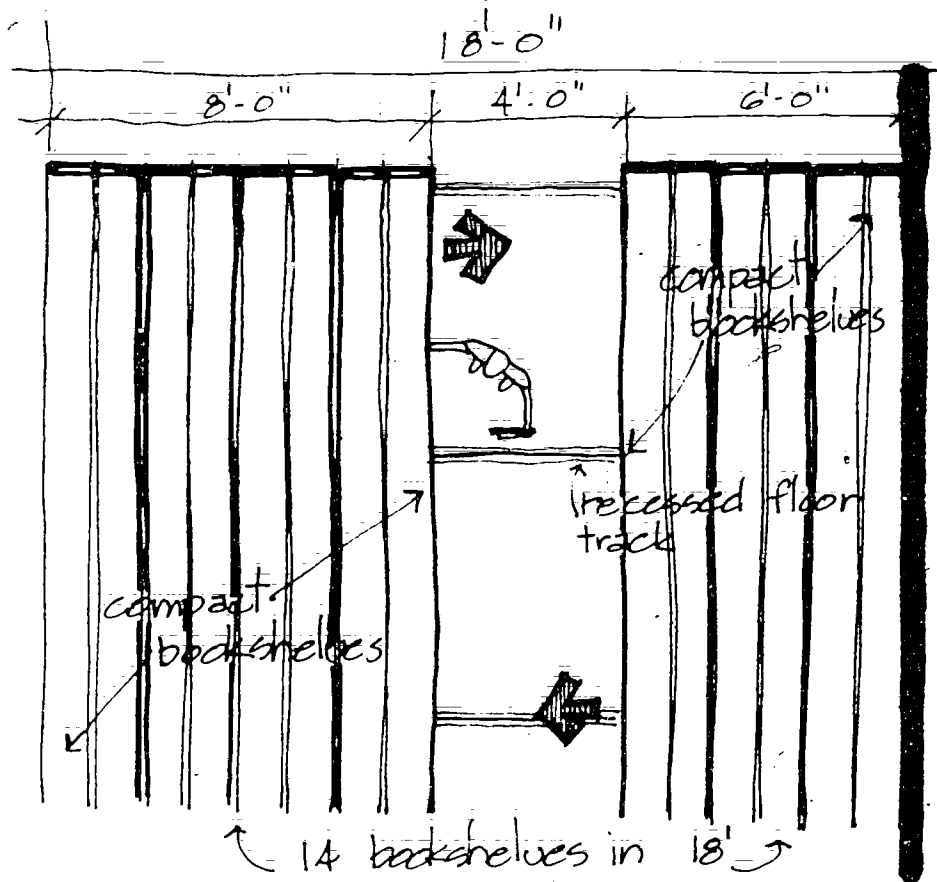

## Compact Shelving plan

Figure 8

### Shipping and Receiving

Shipping and receiving is one of the most important functions of the library operation. A loading dock must service delivery trucks of various bed heights; a standard height of 4 feet is recommended. Truck-bed variations can also be accommodated with an adjustable loading platform (Figure 10). The additional expense is offset by speed and efficiency in shipping and receiving bulk mail. Extreme climatic conditions may also make it necessary to fully enclose the loading dock.

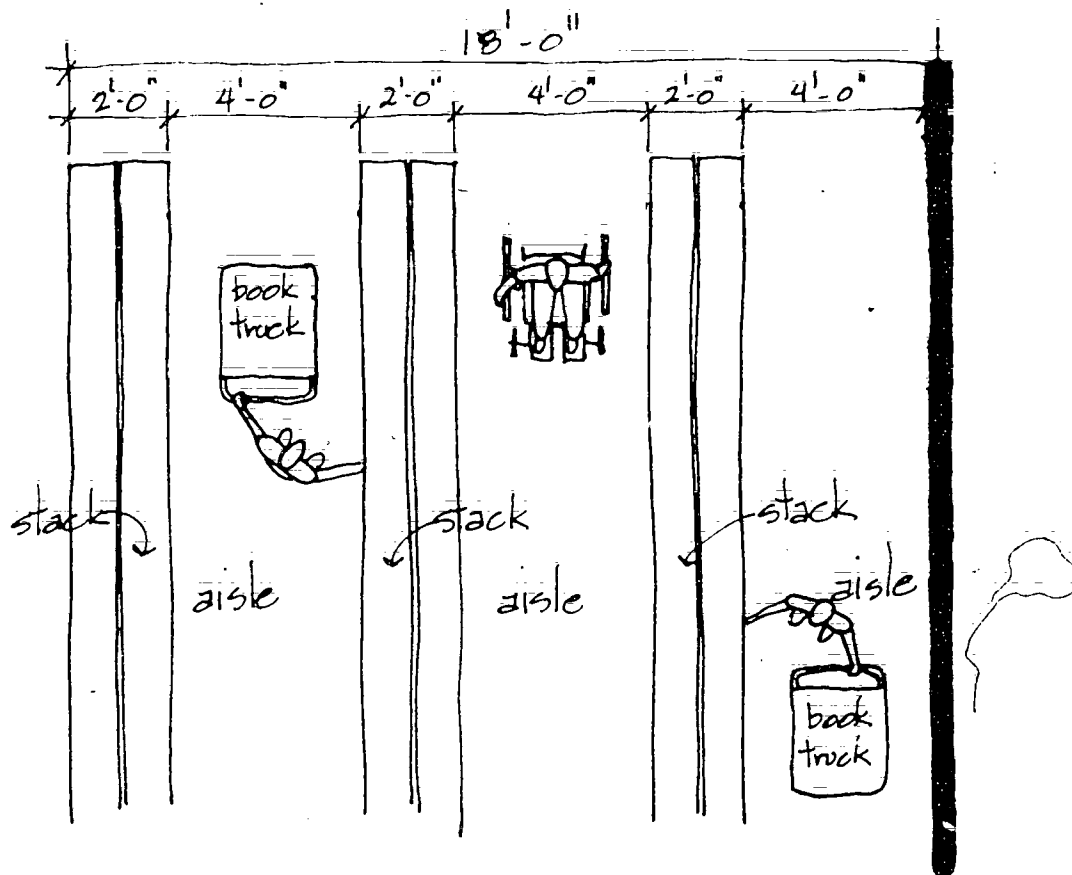

## Standard Shelving plan

Figure 9

### Work Area

Provide a work area with large tables for sorting mail in the book stack area near the dock. The incoming mail is sorted, the cards pulled, and the books either stacked on book trucks for placement on the shelves later, or placed on holding shelves (Figure 11). Provide a special area for inspection of all book materials returned to the library each day. This will include special equipment for rewinding of cassettes, and so forth.

Some librarians have determined that up to 80 percent of the books they receive return to circulation within a short time. A "holding shelf" near the shipping and receiving area thus would save many hours employees

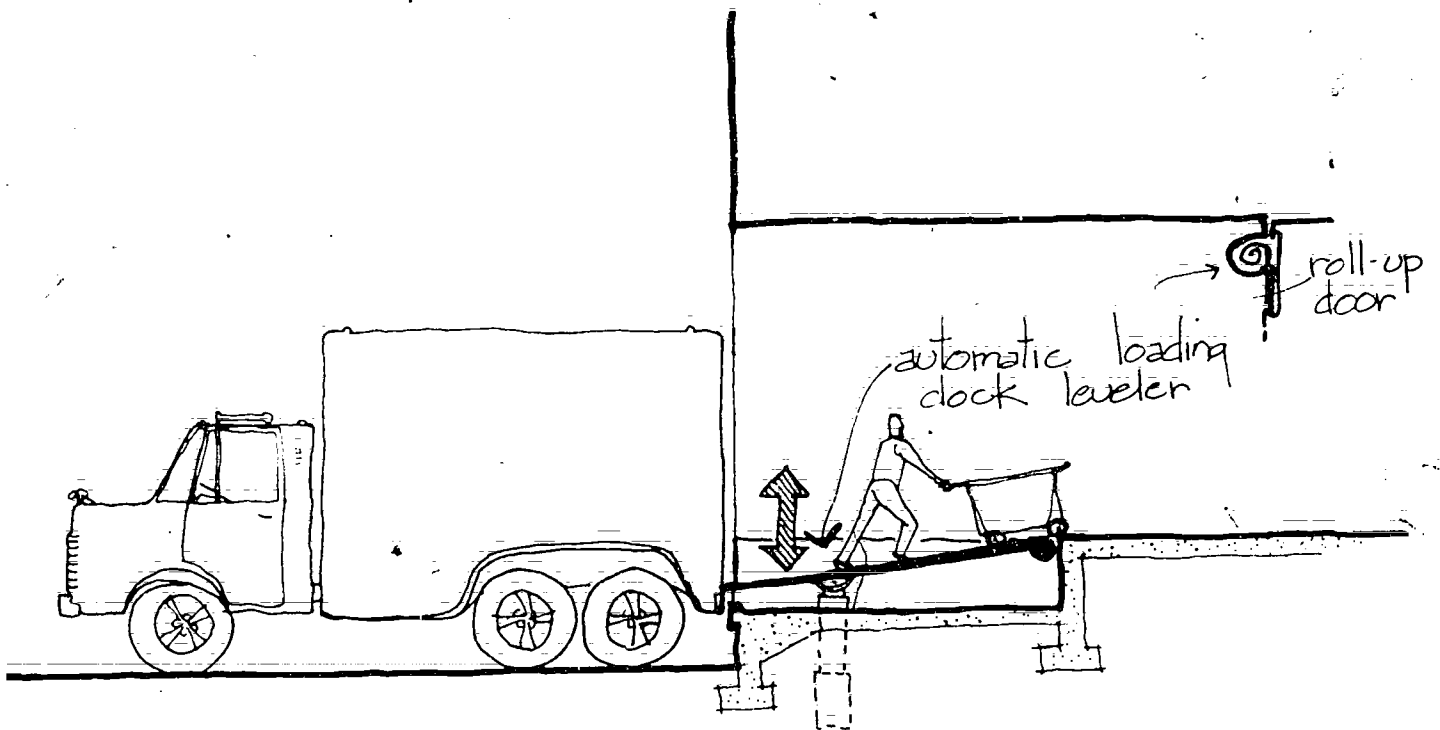

**Figure 10**

ordinarily spend shelving and pulling the same books. The holding area could also accommodate a picking stock of catalogs, brochures, and reference circulars that are frequently shipped to readers.

### ***Freight Elevator***

If a freight elevator is needed to transport materials to another floor, it should be large enough to hold 3 or 4 mail tubs and at least one warehouse employee. The controls should be designed for blind and physically handicapped employees.

### ***Storage***

Adjacent to the work area should be a bulk storage room to hold empty braille containers for future mailing, empty cassette and record containers, bubble pack, cardboard boxes, boxes of catalogs, brochures, and so on. The size of this room will depend on circulation activity (note Appendix A). Even though this room is for bulk storage, some shelving should be available for boxes of smaller items. If a separate room cannot be provided, the bulk storage items can be placed in a designated area of the warehouse.

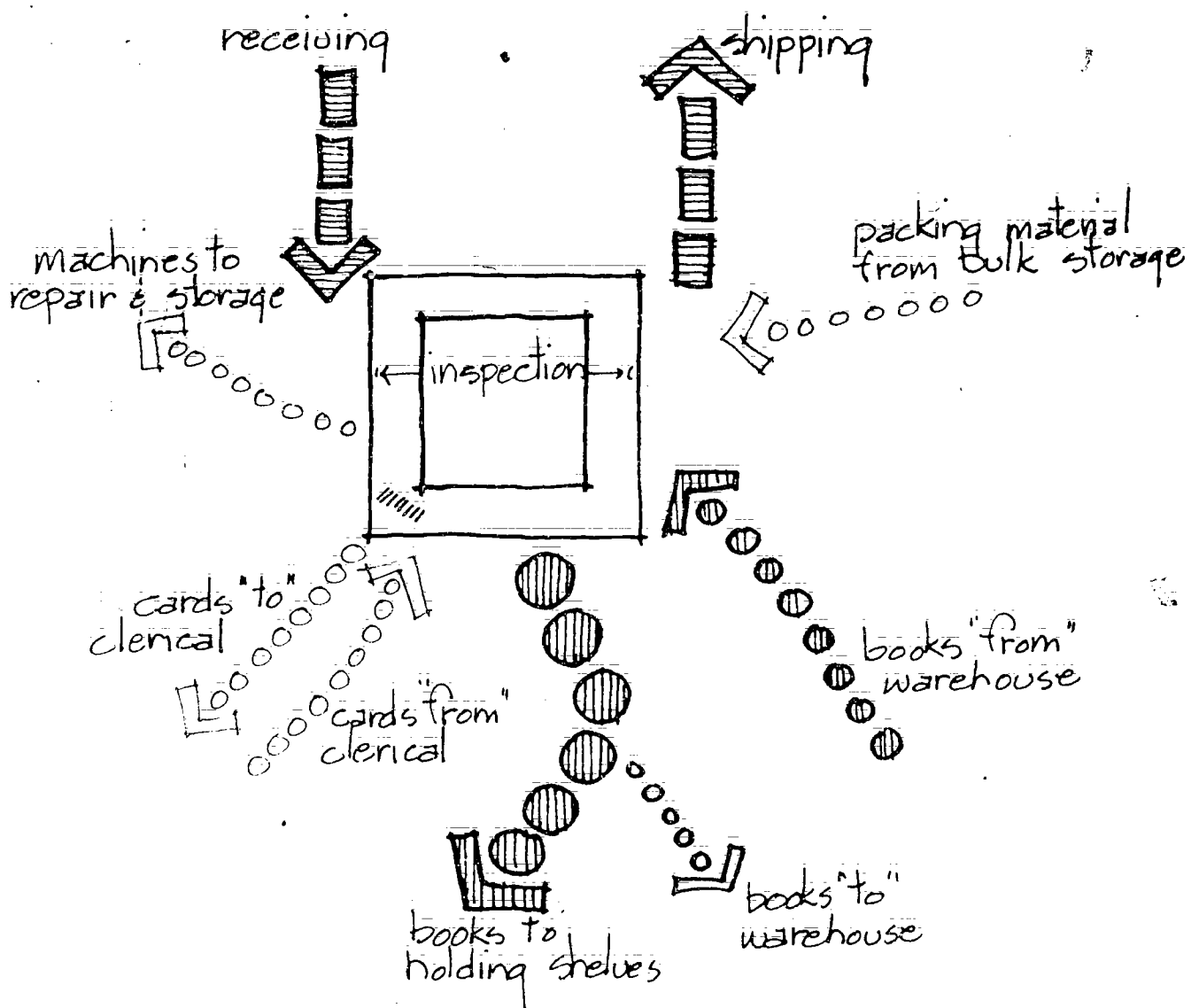

## Flow Diagram of Work Area.

Figure 11

### Computer Room

The use of computers has begun to free staff members from paperwork and permit them to spend more time with patrons. Reader records, inventory, and statistics are going on-line, either fully or partially, in many libraries. If it is possible to install or lease time on a computer, you must provide space for terminals, printers, and disc storage.



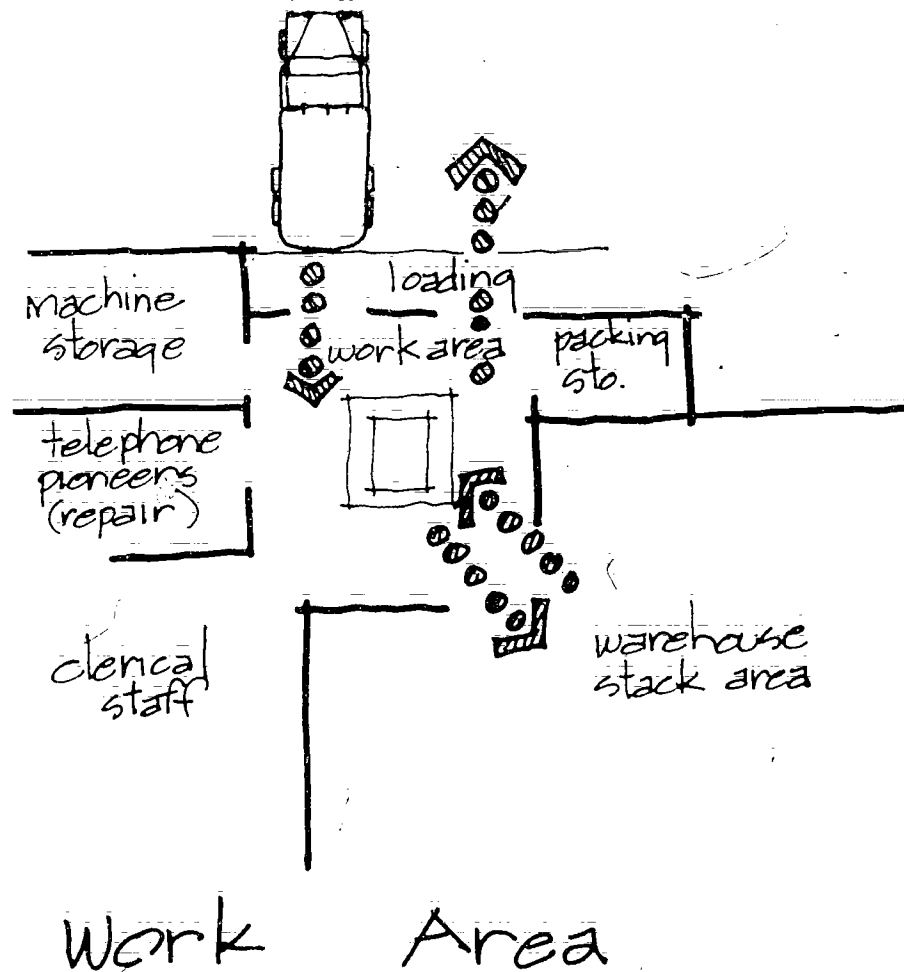

**Figure 12**

Computer space must be planned with the architect, the library systems manager, and the manufacturer's representative of the system considered. Even though specific space for each piece of equipment is designated initially, allow room for expansion—additional printers, terminals, and file storage.

If the systems manager is located in-house, a desk, with files, should be near the equipment. Terminals and printers should have tables with space for power lines and outlets within the table. Conceal all the wires within the walls, above the ceilings, or within floor ducts.

### ***Machine Repair Room***

Talking-book and cassette machines are often returned to the library broken or damaged and requiring adjustments and repairs. Provide space

within the building, preferably near the shipping and receiving area, for repair work by staff members or volunteers (Telephone Pioneers or others). This room should be separate from the rest of the library and locked; the tools used to repair the machines and the spare parts are expensive. Adequate space should be provided for training repair people (Figure 12). Contact NLS machine repair specialists in the early planning stages for guidance concerning work bench location, lighting, electrical outlets, and other special needs.

### ***Machine Storage***

It is useful to have the machine storage room located near the shipping and receiving area. The machine storage room should be climate controlled with low humidity. It should also be locked because machines must be stored securely. The machines can be stacked in their shipping boxes (at least 8 boxes high) on the floor as high as the ceiling will allow (or at least up to 20 boxes high where ceilings are very high); without the boxes, the machines can be stacked 6 high. An 8-foot ceiling height should be adequate. The cassette machines must be charged; therefore, provide additional shelving and 110V outlets or plugmold for charging at least 20 to 25 machines at one time. The number of empty shelves for charging will depend on the rate of machine turnover. Include additional shelving for convenient storage of headphones, pillow phones, and other accessories.

### ***Audiobook Production Center***

To provide an in-depth book collection, the network library may wish to produce additional titles and magazines of local interest. To produce open reel and cassette tapes requires high-quality recording equipment. A number of manufacturers supply equipment for audio production. Contact the NLS audiobook production specialist in the early planning stages for guidance on layout, equipment needed, and other special needs.

Space for at least one sound reduction recording booth, approximately 6 feet square, should be provided. Specialized recording programs may require larger booths. Purchase a commercial booth rather than trying to build one. Conceal electrical connections for the booth's life-support system, microphone, and intercom. The audiobook production area must be away from the library's traffic pattern and protected from extraneous noise. (For additional details on recording booth site location refer to *NLS Update* May-June 1980, Vol. 3, No. 5.)

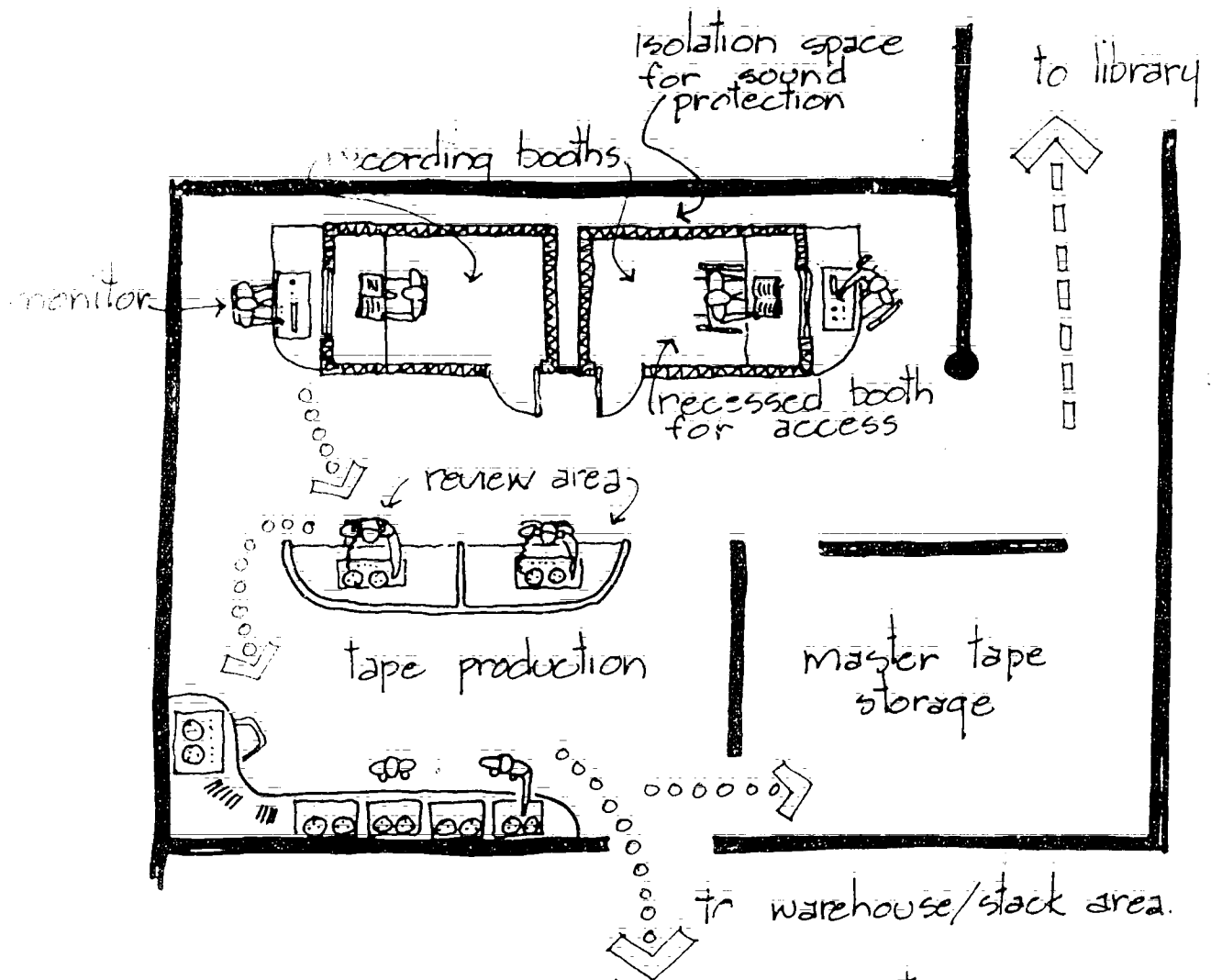

## Audio Production Center

Figure 13

For each recording booth there must be appropriate recording equipment. This equipment is placed outside the sound reduction booth, at a comfortable sitting height, in front of the view panel. The equipment can be placed on a table or a built-in counter. The floor of the entrance to the sound reduction recording booth may be recessed to allow a wheelchair to enter; however, the booth cannot be fully recessed as the lip of the door overlaps the opening.

22 Near the recording space should be an area for reviewing the recorded tapes. This reviewing section should also be removed from the main traffic

pattern. You can place the reviewing equipment on work counters; however, hanging carrels would provide access to reviewers with wheelchairs.

Adjacent to the recording and reviewing area should be a tape duplicating work room. The network librarian, in consultation with NLS, can best determine the amount of equipment and space required. The equipment should be placed on 36-inch-high work counters for easy access, maintenance, and operation. Provide sufficient counterspace for future expansion:

Store open reel and cassette masters in a temperature- and humidity-controlled room and provide for their security (Figure 13).

#### 4. Site Selection

With the architect as a member of the planning team, review the total functional program, including the construction budget, furnishings, equipment, programs within the library, personnel, and space requirements. The architect will want to know about the proposed building site, which may have been purchased or acquired before the planning process started. (If this is the case, give all the architectural firms interviewed the opportunity to visit and acquaint themselves with the site and its surroundings.) If a new site is to be acquired, the project architect should help select it. The architect should be experienced in analyzing property for accessibility from main traffic arteries, proximity to public transportation and postal services, and availability of utilities on or near the site. Many times a site is purchased or donated only to find that one or more of the utilities is not available, necessitating the exorbitant cost of extending lines to the site.

If a new site is to be purchased, the seller should provide, as a condition for purchase, a topographic survey. This map will let the architect see, on paper, the shape of the lot, its contour and elevations. It is easy to look at a piece of property and say that it is "dead level," but the topographic map can reveal distinct differences in the property. Contour and elevations influence building location and floor elevations, thus affecting building costs.

Another condition of the purchase contract should be the site's ability to pass soil bearing tests. The site may look acceptable from the surface, but may be filled with rock, thus rendering it prohibitively expensive to excavate. The soil report may reveal that the soil is soft and spongy, or not sufficiently strong to hold a building without an engineered earth fill, caissons, or other costly foundation supports.

When the conditions for the site are acceptable, the architect can sketch the building location from the topographic survey, using the approximate building size from the planning program. Roads and drives onto the site, parking requirements, and expansion possibilities can also be shown in sketches, thus helping the planning team decide on the proper site for the proposed library.

## ***III / Architectural Program***

The role of the architect takes on more meaning as the time comes to judge the size of the allocations for the various functions, assign those spaces, and prepare the architectural program.

### **A. Programming**

After conferences with the agency director and librarian, one of the first steps in architectural programming is relating one function to another: the relationship of the patron reading study area to the reader advisor's, the clerk typist to the warehouse, the librarian to the conference room, etc. The architect may use bubble diagrams (Figure 14) to show this relationship. These bubbles will show the proportions of the proposed space and provide flow diagrams showing the relationship of one area to another. (Note Flow Diagram, Appendix C.) As these sketches evolve from fluid diagrams into those showing more definitive spaces, the architect will relate the building outline to the site. Entrances and exits, location of parking, and the entrance of utilities into the building are planned. Broad overview line drawings will show specific entrances into the building, service and loading docks, and landscaping.

### **B. Schematic Design**

After the planning team reviews and approves the drawings, the architect will begin schematic design drawings. These are usually drawn to a scale of 1/16th inch or 1/8th inch equals 1 foot. The schematics will more clearly identify the relationship of the building to the site. The entry, lobby, reception, staff offices, corridors, restrooms, audiobook production center,

25

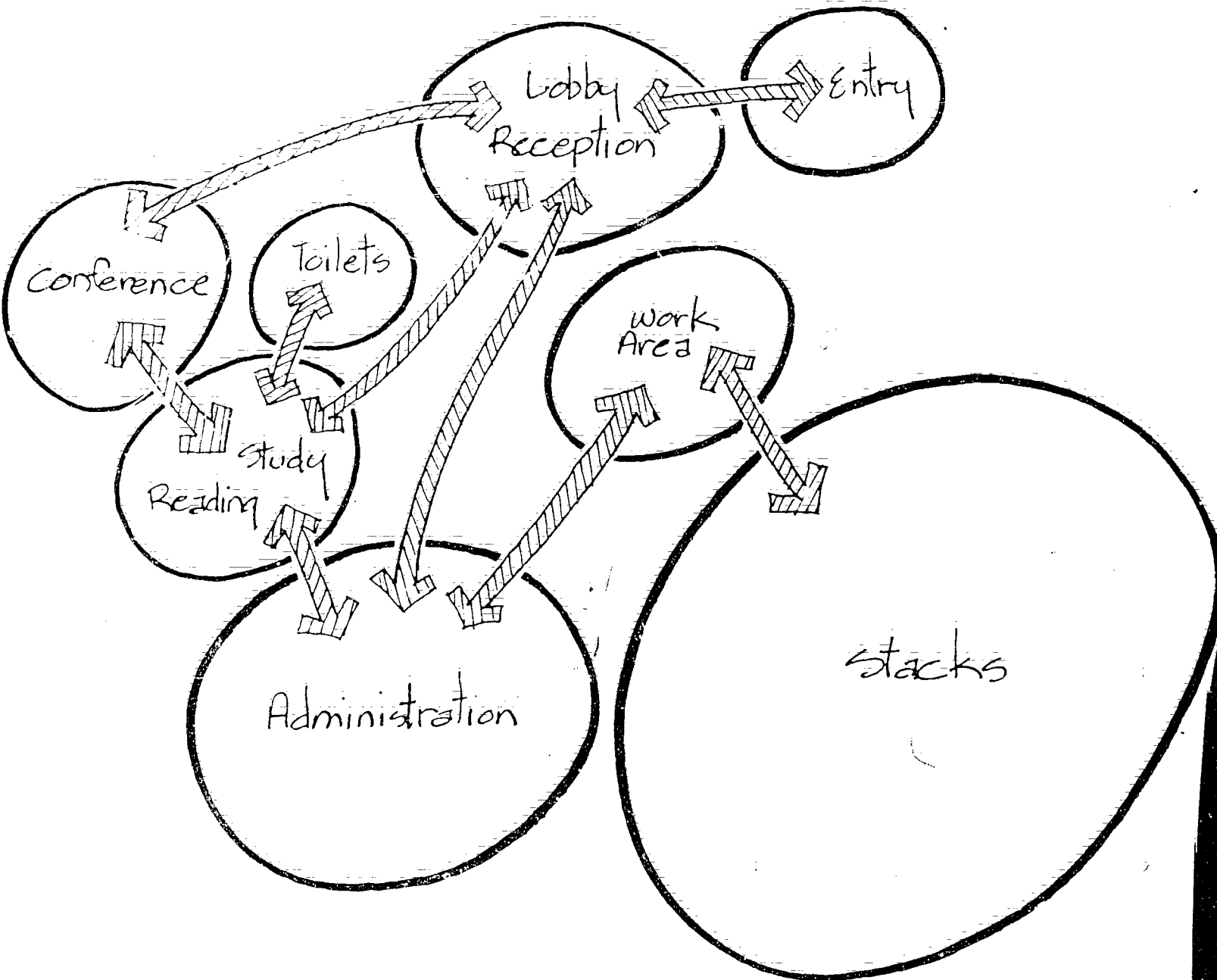

Figure 14

bookstacks, and various other features of the library will be shown, with their relationships to each other (Figure 15). Concepts of the exterior elevations of the building form as the architect masses the interior relationships. Suggestions of building materials are noted on the elevations, as well as locations of doors, glass, and landscaping (Figure 16).

During this development stage, the architect will plan more definitely for barrier-free design: encompassing the proximity of patrons to the main entry; the use of ramps or sloping walkways, handrails, and doors; and the ability of blind and physically handicapped patrons to move freely. Even though the emphasis on barrier-free design is for patrons, employees may also be visually or physically handicapped. Thus, the ease and comfort of blind and wheelchair employees to move freely from one work area to another, from the administration area to the bookstacks, from the conference room to the restrooms, and to and from the staff lounge must be planned practically and sensitively.

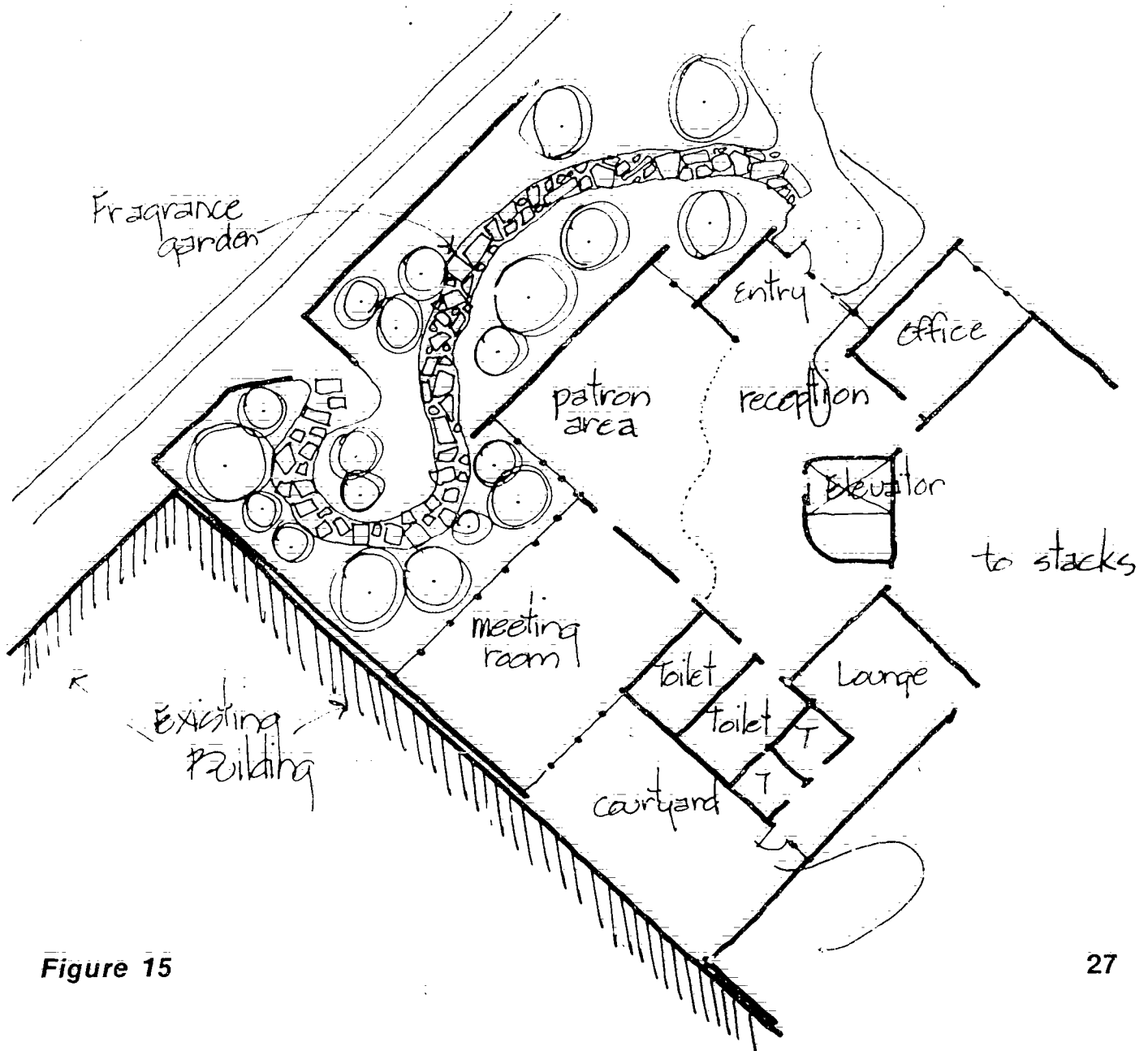

Figure 15



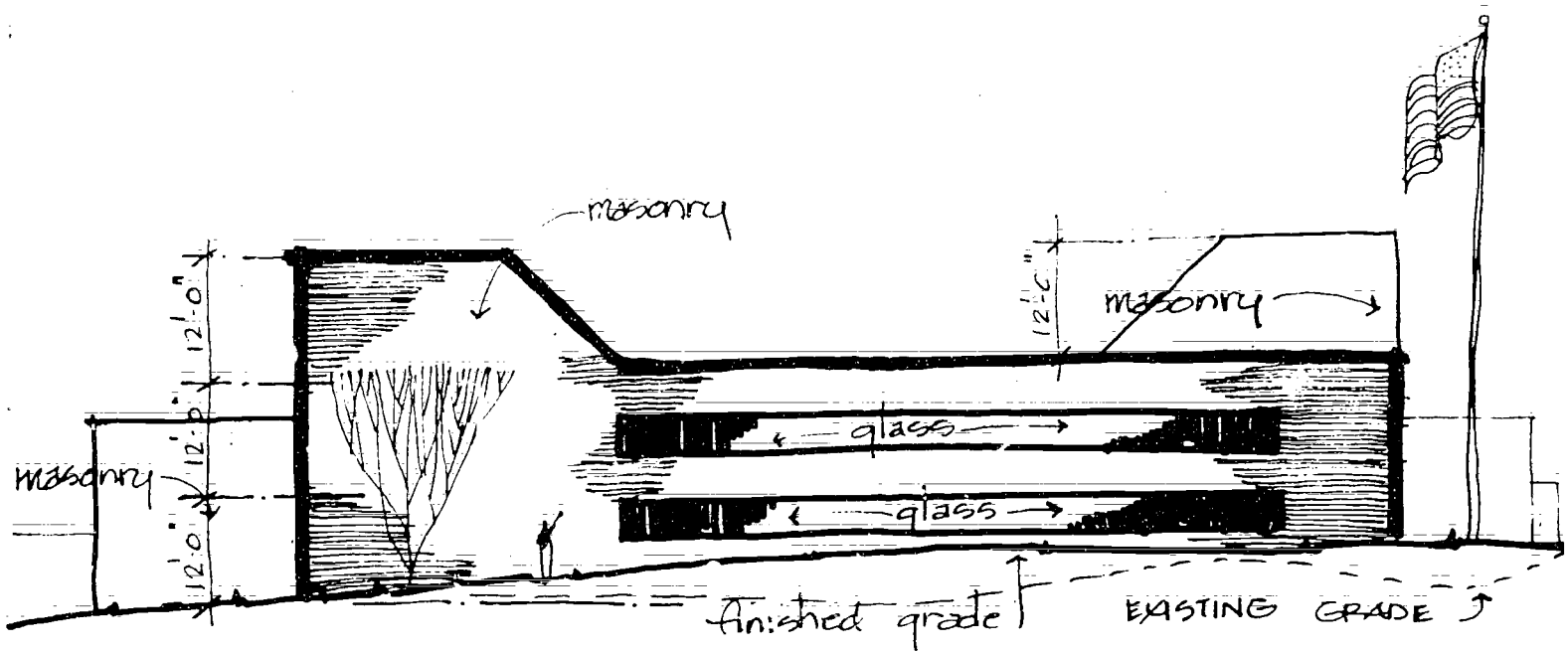

Figure 16

### C. Design Development

After the schematic design drawings have been approved by the planning team, the architect begins the design development. The rough sketches and line drawings show more function and detail. The drawings are enlarged to 1/8-inch and 1/4-inch scales. The floor plans show thicknesses of walls, partitions, doors, windows, and fixed and movable furniture. The support systems such as janitorial storage, bulk storage, elevators, mechanical equipment, and stairs are shown in greater detail.

### D. Working with Consultants

At this point, the architect will begin consulting with the engineers. The architect and structural engineer will plan a framing system or main structure that will be economical, yet provide the open spaces required for libraries. Of particular concern will be column locations and how these relate to the siting of stacks, offices, and reading areas. Close communication in the early drawing stages prevents many headaches and disappointments when it is too late to make adjustments. The architect and structural engineer will make several recommendations concerning the use of a steel or concrete framing system. These professionals are familiar with the economics and availability of materials, and can assist the planning committee in making decisions.

Mechanical and electrical engineers are also brought in at this time. All rooms must be air-conditioned and ventilated, but a direct, positive air flow (draft) will usually generate patron and employee complaints. Thus, the engineers will need to plan the best locations for air supply and return according to the placement of people within the building. The architect's design development drawings will show the locations of the staff and patron areas, desks and work areas, and the required lengths of ducts from the mechanical equipment room. The engineers must also be informed of any special ventilation and air-conditioning requirements, such as for equipment or master tape storage which requires constant temperature and humidity.

At this early stage, the electrical engineer will also be able to plan power requirements and power loads. Lighting will be selected for reading and work areas as well as for the special, aesthetic lighting. Lighting around the building area for walks, parking, and security will be discussed and designed. All of these engineering plans will be discussed with the planning team, and their input relating to structural, mechanical, and electrical systems will be considered.

#### **E. Preliminary Drawings**

From these meetings and conferences with engineers and planning team members, the architect will organize, into outline specification form, the various materials and subcontracts to be used within the building. The basic structure, exterior materials, roof type, various kinds of doors, ceiling system, floor finishes, wall finishes, glass, and glazing will all be shown. Any special finishes or treatments will be noted, as well as special equipment, cabinet work, or built-in furnishings. The architect will take the design development drawings, together with the outline specifications, and prepare an estimated building construction budget. The architect will know the anticipated construction date, so an escalation cost will be included if construction is more than one year away. Also, the architect will add a contingency of approximately 5 to 8 percent onto the construction cost. This figure may be refined later in the project as the drawings develop and details are determined.

In planning a total project cost, the estimate should include a figure for furnishings, shelving, and special equipment. These items will have been discussed during the schematic design conferences, so the architect can determine the amount to be budgeted.

## F. Barrier-Free Design<sup>1</sup>

While the design development has been underway, the architect will continue barrier-free design detailing. Curbs are a hazard to everyone, but this one step is insurmountable to someone in a wheelchair. With this in mind, the architect will provide a ramp or level entrance from the parking area. If it is essential to have a curb, it must be broken with a wide ramp. Install a handrail at the entry and within the building, leading to various rooms. Use braille descriptions along the handrail to identify the rooms (Figure 17).

Plan entrance doors for ease of access. An automatic sliding door is preferred. Doors similar to those in most supermarkets would be best, as handicapped individuals are familiar with their operation. Do not use a revolving door. A swinging door is also unacceptable unless a handicapped control is provided (Figure 18).

Change floor covering (such as from vinyl asbestos tile to carpet) to help blind individuals identify areas or entrances to a room. For easy wheelchair movement, there should be no pad under carpet. Vinyl asbestos tile, concrete, and wood indicate clear areas to blind people; carpet indicates obstructions such as furniture (Figure 19):

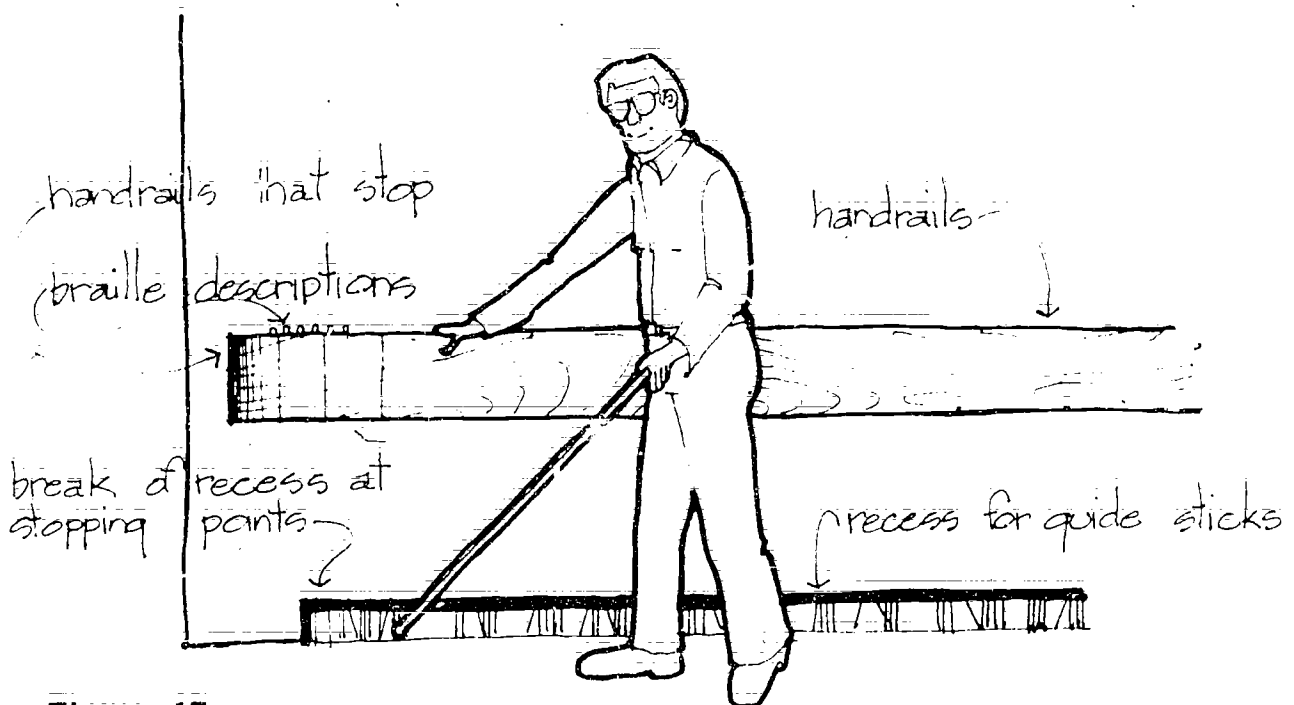

Figure 17

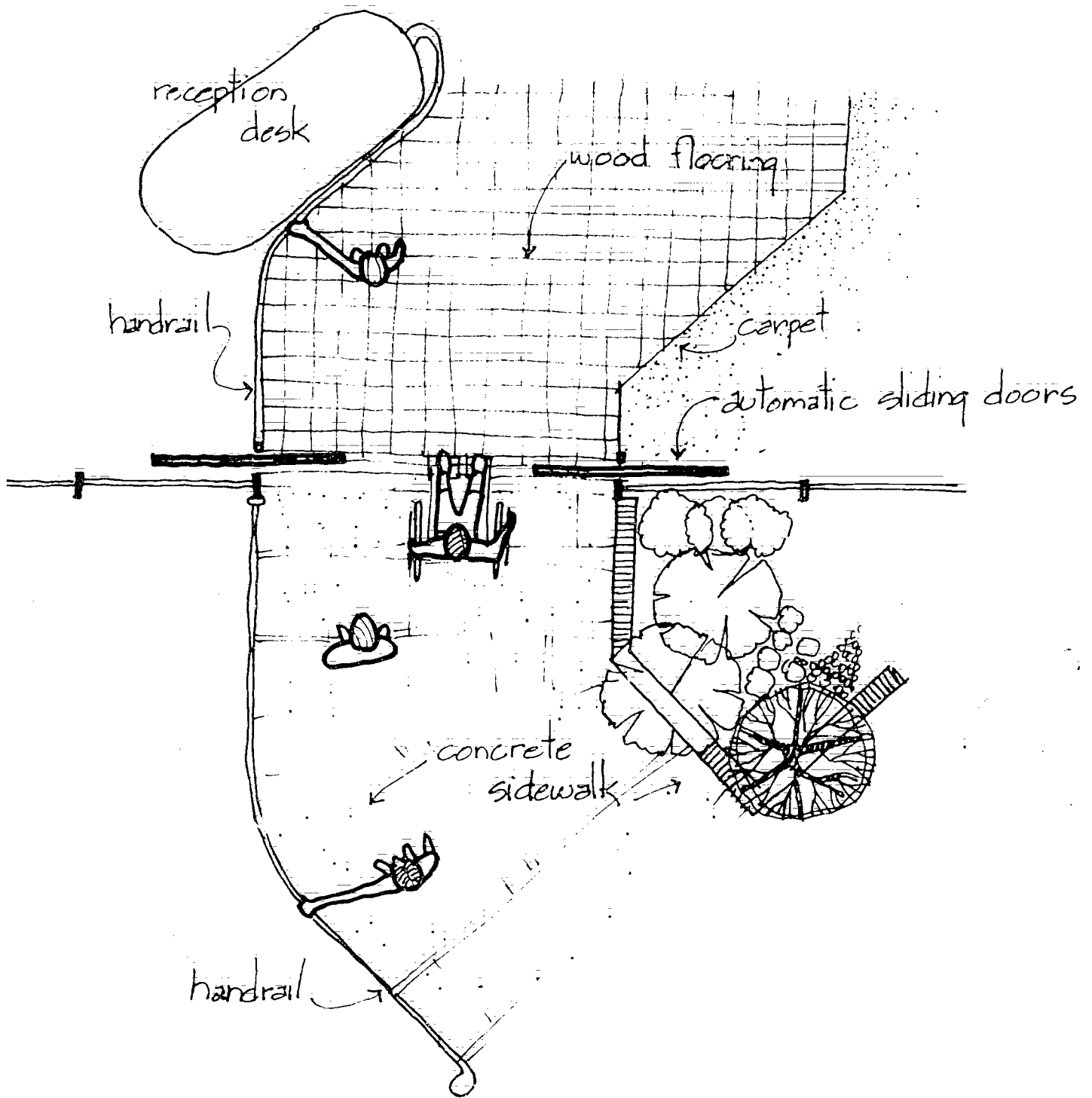

Figure 18

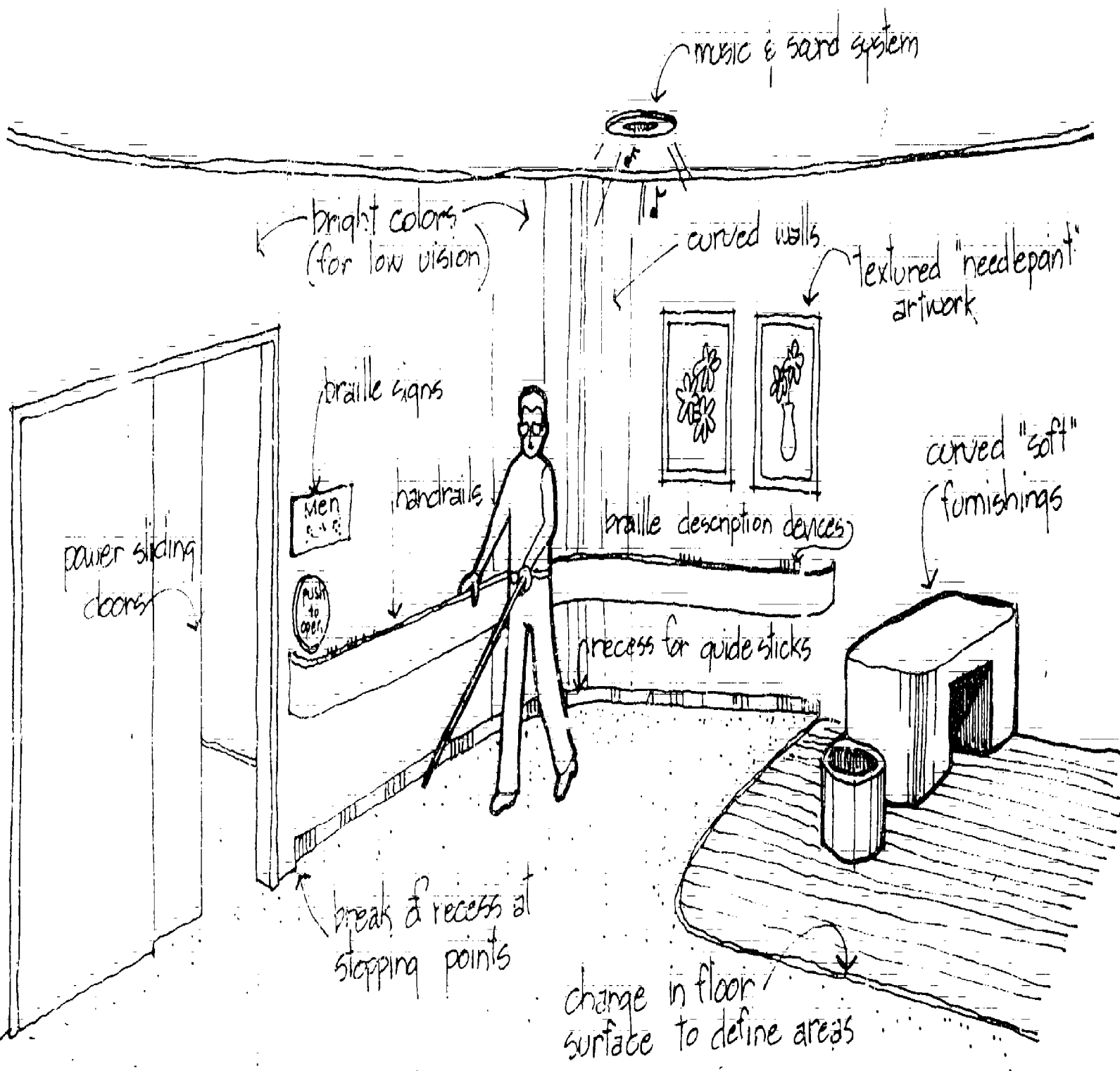

Figure 19

Specify the height of water fountains, light switches, and door handles from the ANSI<sup>2</sup> or OSHA<sup>3</sup> codes. Door widths to rooms should be wide enough to allow a wheelchair to move through easily. A horizontal door that slides into the wall is preferable to a standard door that pushes or pulls open (swinging door). Large raised numerals as well as braille identification should be used adjacent to elevators to identify floors.

The restroom and staff lounge areas cause physically handicapped individuals the most difficulty. Lavatories must be placed at convenient heights, with easy-to-reach faucets, tilted or low mirrors, and recessed insulated pipes to avoid burning their legs.

Even though codes require toilet stalls large enough for the handicapped, as well as handrails, there is never quite enough room to manage adequately. Do not cut this space in the library; devote an entire toilet stall to wheelchair users, complete with built-in lavatory and mirror (Appendix B).

In the staff lounge, provide legroom under the counter so a wheelchair can roll under it and its occupant can prepare food. Arrange the furniture in the lounge so that blind and physically handicapped individuals can maneuver easily. Sharp corners are a detriment to both blind and wheelchair-bound individuals; ease or round off these corners.

Color throughout the building is not only pleasant for working conditions, it should be restful to employees or patrons with low vision. Sound devices afford pleasure to blind or visually handicapped individuals, as do music or water fountains, although the location of a fountain must be handled carefully.

It may be possible to have a fragrance garden near the entrance to welcome users and staff to the library. Emboss the names of the plants on braille plates (although this can be an expensive extra). The garden could be located in a number of areas besides the entrance; on a patio or inside in the waiting area. The architect can help select the best location.

## G. Contract Documents

The design development drawings, outline specifications, and estimated project costs should be reviewed with and approved by the planning team before the preparation of the final contract documents. These final documents are usually referred to as "working drawings," because they give the specific dates and details required for construction. The architectural

<sup>2</sup>American National Standards Institute

<sup>3</sup>Occupational Safety and Health Administration

drawings, together with the structural, mechanical, plumbing, and electrical drawings and their specifications, make up the documents on which general contractors will bid. These documents with the standard agreement between the owner and the contractor are part of the contract the administrative agency will sign with the successful bidder.

## II. Approving Agencies

Before requesting bids, the architect will take or send the working drawings and specifications to the approving agencies. If this project is funded with Federal money, the required approving agencies are listed in the Federal program. The state, as will the local governing authority, will usually require a review of the final documents. Many times, the architect will send a copy of the design documents (preliminary drawings) to the appropriate authorities so they will be briefed on the project. Then the architect and the agencies will have already established some communication regarding the project and it can be reviewed for code compliance before final drawings are complete.

### I. Bidding and Negotiation

With the final drawings and specifications complete, the architect will recommend several methods for obtaining bids. Most libraries are funded with Federal, state, or local money, and any licensed contractor in the state qualified by the licensing board for this type of work must be given the opportunity to submit a bid.

After completing all the pre-bidding requirements, the architect will prepare an advertisement for bids to be published in the local paper. The notice will call for bids at a specific date, time, and place. Bids will be opened and read publicly at that time. The public bid opening is required if the project is funded with public funds.

After the bids have been opened and read, the architect will advise the administrative agency of the low bidder and of that firm's prior work and performance. The architect will note, on that contractor's bid, the number of days for completion of the building, which bonding company has underwritten the contractor, and when the general contractor can begin work. Note that it is usually difficult to refuse a bid from a general contractor unless there is documentary proof that the firm is incompetent, has bad management, or is not able to be bonded for the projected building cost.

After reviewing these bids, and, if the project is within the planned budget, the administrative agency will enter into a contract with the successful bidder. The architect will then prepare the required number of contracts.

The type of contract to be used can be furnished either by one of the funding bodies or by the American Institute of Architects (AIA), which has written a "Standard Form of Agreement Between the Owner and Contractor." The AIA contract is accepted by the architectural and legal profession and by most associations of general contractors.

If the governing body has private or conventional funding sources, the architect and the administrative agency may be able to establish a list of acceptable general contractors and invite them to bid on the project. Such bids do not necessarily have to be opened publicly. Or it may be possible to negotiate with a general contractor, knowledgeable in the type of construction proposed. Then the contractor is familiar with the building during the various drawing stages. Such early negotiations with a contractor can be risky; competitive bidding is the safer route.

After the successful general contractor is determined, the architect will proceed with an owner-contractor agreement, as outlined earlier. This agreement, together with the final drawings and specifications, becomes the contract document used to build the library.

### 3. Construction

Now that the successful general contractor has been selected, the architect will organize a preconstruction conference to establish the time schedule with the construction superintendent and all the subcontractors. The architect or a representative who will act as the field observer will outline procedures for payment requests, change orders, and correspondence within a proper sequence and time order.

The field observer will periodically visit the site, observe the construction and submit reports to the general contractor. These reports will also be circulated to the owner, appropriate Government agencies, and routed in the architect's office so that key personnel can be kept aware of the progress.

One of the architect's responsibilities will be to approve monthly requests for payment from the general contractor. From the periodic observations, the architect will determine the percentage complete on the project and the amount of materials stored at the site. If the various workers



and subcontractors have completed the work for the amount requested, the architect will approve the request and submit it to the owner (administrative agency) for payment. These requests will also signal the need to upgrade the time schedule and completion date.

Sometimes changes made at the direction of the owner can extend the time schedule; inclement weather conditions can also affect the timing. Materials and supplies may not be obtained as readily as scheduled which also may affect the time schedule. In any case, the construction schedule should be reviewed either at each request for payment or when a request for a change order (a request for an alteration in the construction process) is submitted. Change order requests normally originate with the architect and administrative agency; they can add substantially to the construction cost and time schedule and should be avoided if possible.

Throughout construction, the architect's office will receive shop drawings and samples of various pieces of equipment that must be approved for job installation. These items should be discussed with the building team, so that its members will know the progress and current status of the project.

## K. Summary

The decision to build a new facility is a positive and emphatic statement that new directions, new programs, and new challenges await the administrative body, the librarians, the staff, and the patrons. The responsibilities laid before the planning team for this new facility are immense and time consuming. There is no bypass around the time schedule and procedure. Follow the steps outlined in Appendix E. This schedule sets forth a deliberate and orderly process to achieve the goals entrusted to the planning team.

## ***IV / Renovations***

It is not always possible to build a new facility; continuing escalation of construction costs is a basic problem confronting most administrative agencies in their search for new facilities. Other reasons can also force agencies to look for space in an existing building. In such a case, the library's program should be studied thoughtfully. The functional program previously outlined should be followed, with emphasis on the existing facility. In lieu of the site selection process, the architect should analyze the existing building or buildings proposed for renovation and present findings to the planning committee.

If the board is considering several buildings, the architect should evaluate each site on its own merits, checking to see that the buildings are of sufficient size to meet the functional program requirements, planning expansion, staff to be employed and patrons to be served.

### **A: Site Suitability**

Vehicular accessibility to the building by the interstate highway system will interest suppliers who ship books to and from the warehouse. The ease of pickup and daily book deliveries will enhance the flow of the library process and provide quicker service to patrons.

If the building is in a central urban area, accessibility would not be as much of a problem as the building's actual location (Figure 20). Security for the building and its contents is certainly a concern, but the safety of employees and patrons is a first consideration.

Check with city officials for a master plan to see if future development is planned for the surrounding area. If a master plan is not available or

**37**

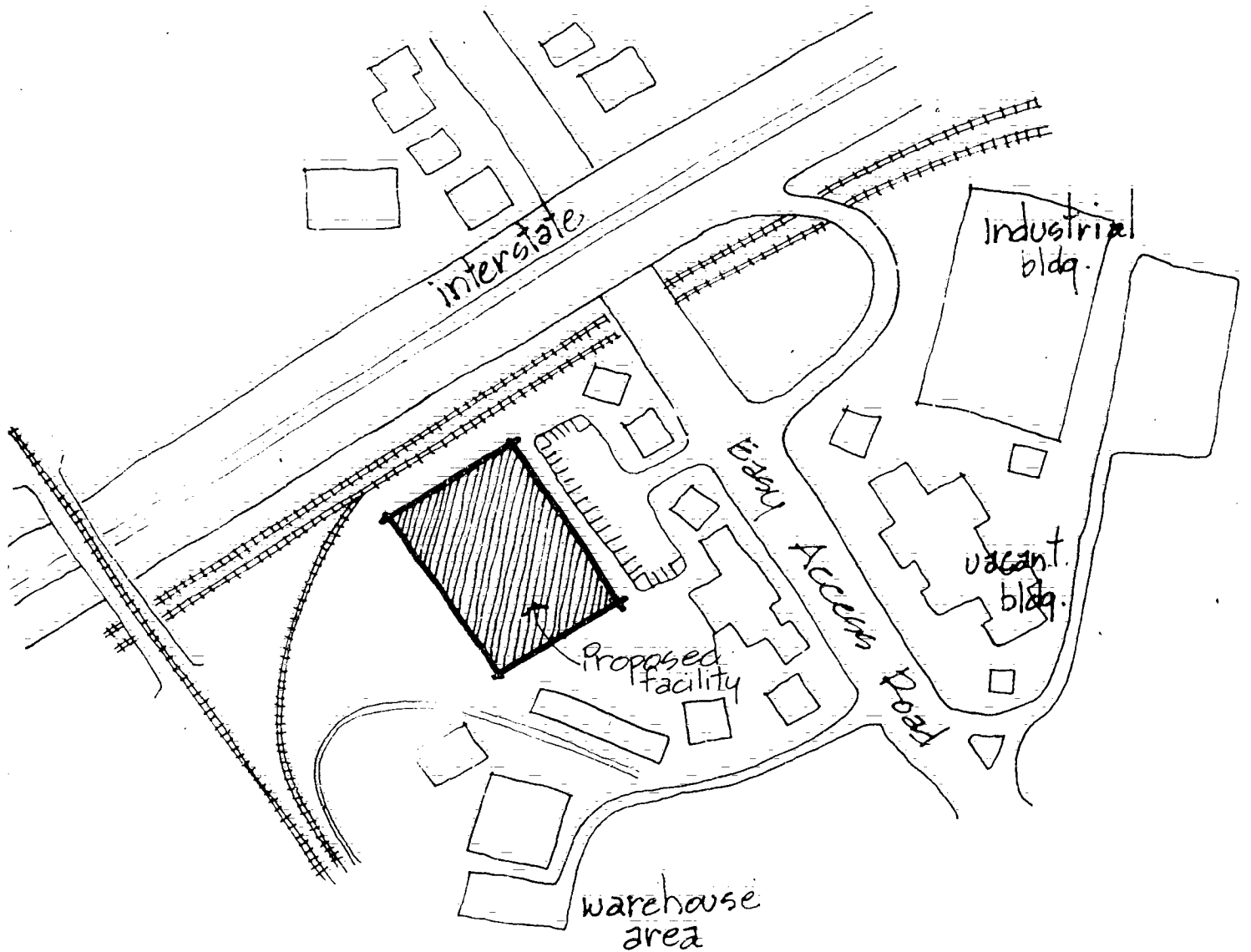

Figure 20

current, the architect should ask other professionals, city officials, the Chamber of Commerce, and developers about the projected growth for the proposed neighborhood (Figure 21).

One consideration is the building's accessibility to patrons who may be able to visit the library, as well as to family, friends, and other interested parties. The barrier-free program already described is equally important in a renovation. Likewise, the standards set for the functional program in a new building apply also to a renovated building.

One consideration that is important in some states is the library's proximity to other Government buildings. Many directors place a high priority on this decision, because they want Legislators and Government officials to be able to attend conferences within the building to be aware of the presence and the function of the network library.

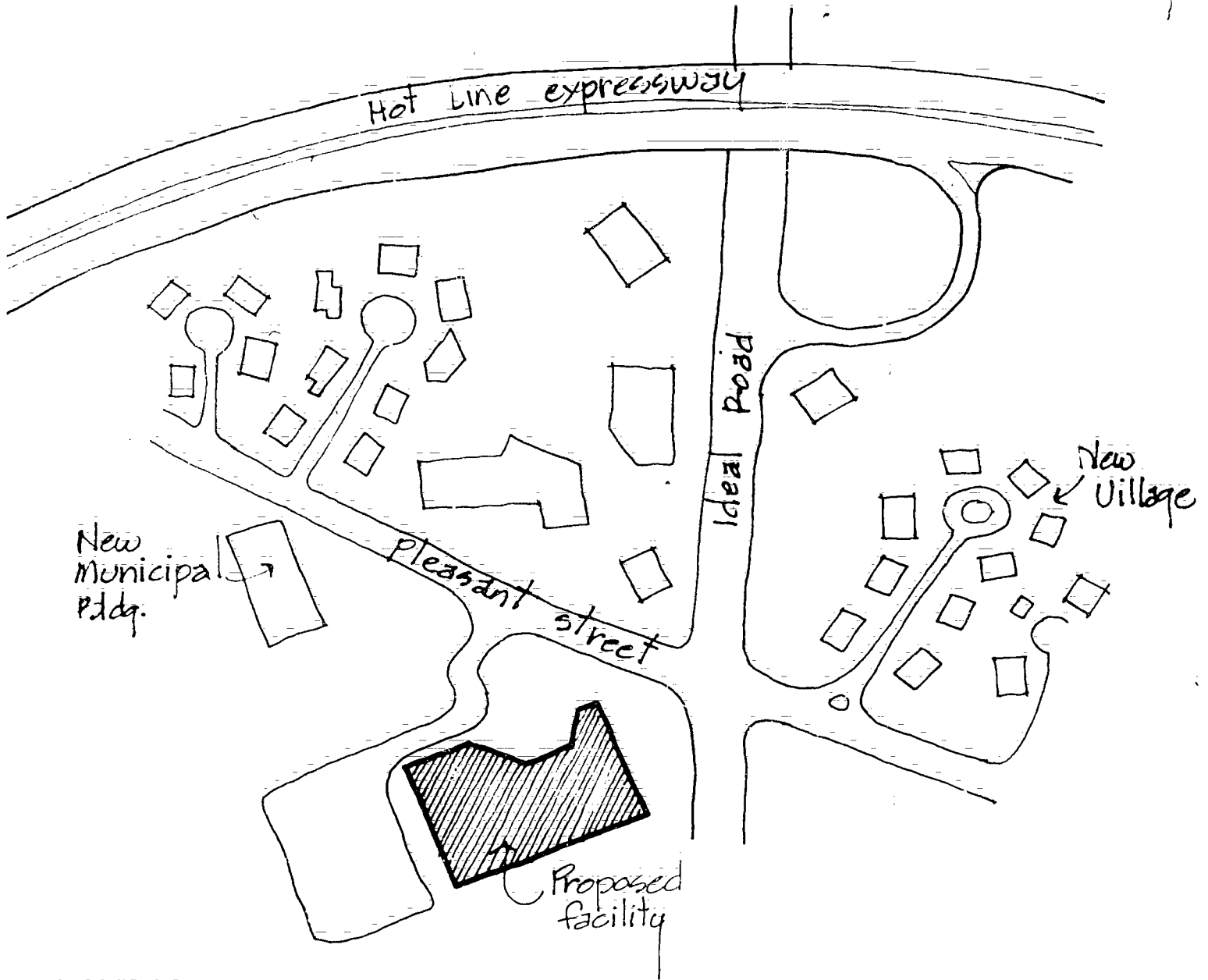

Figure 21

## B. Analysis of Existing Services

An existing building should already have services from all utilities, but these must be investigated. Requiring a site survey showing the utilities is usually standard procedure before consummating a sale. Check the site to see if the sewer line is connected to the public sewer rather than to a septic tank or private system. The size of the water lines, the gas main and its pressure, telephone, and electric power lines should all be shown on the survey.

### *Structural System*

A prime consideration should be the condition of the structural system. The architect will make a preliminary investigation of the soundness of the building and will then engage the services of a consulting structural engineer to confirm and expand on the findings. Usually the local building inspector will investigate the building; this individual can be of enormous help in providing historical records.

Of utmost concern will be the stress placed on the structural system by the library stacks. The consulting structural engineer will investigate and analyze the existing structural framing system to see if new load requirements of the library can be placed within the framework of the existing building. If the floors cannot withstand fully loaded library shelving, the engineer may be able to correct the situation with some modifications. A decision for modification to support the shelving load must be balanced against other considerations of a building.

The outside walls and their material make-up will be noted by the architect, as well as their current condition. Exterior wall surfaces that require treatment every few years can be an expensive maintenance problem and a drain on the planned operating budget.

If the building is more than fifty years old, water may have seeped through walls or around windows and doors. Check for infiltration of water, from either walls or roof. This condition can plague occupants for years.

The roof will also be of prime interest to the architect. A flat roof nearly always presents water problems; either the flashing around the curbs and gutters has deteriorated, or the wall flashing around the parapet walls has cracked and opened. Many times, the gutters and downspouts are in poor condition and will cause surface water to accumulate; or old roof drains have become plugged.

The architect will note all these items relating to the envelope of the building. The fewer structural repairs required, the greater the savings.

### ***Electrical System***

The architect and the consulting electrical engineer should analyze and evaluate the electrical service within the building. Many times, the electrical service to the building was planned for a limited occupancy, such as for a warehouse, which did not require a large electrical load. Furthermore, the building may not have been planned for air-conditioning which is a common problem or the additional electrical loads required by a library. If the service is not large enough, new entrance panels and proper wire sizes will have to be added. The engineer will check all lighting panels, condition of wires, size of wires, and so on. In any event, the electrical system will have to be brought up to standards of the National Electrical Code.

### ***Mechanical System***

The consulting mechanical engineer will investigate the existing heating and air-conditioning system. Many times an older building does not have a cooling system and the heating system may be an antique. Consequently, the engineer and architect decide whether to recommend purchasing a new heating and air-conditioning system rather than renovating an existing one. Sometimes controls can be installed on an old boiler, new thermostats installed on old radiators, and a new, separate, air-conditioning supply installed. Each building must be analyzed individually by the architect and the engineer to find an economical method to cool and heat it adequately and comfortably. In any event, heating and air-conditioning comprise a major cost of any renovation (approximately 20 to 25 percent) and must be thoroughly investigated.

### ***Plumbing***

The architect and the consulting mechanical engineer must check all water, gas, and waste lines in the building to see if they are of adequate size. The existing pipes and drains should be checked to ensure that they are free of rust and not deteriorating. The number of restroom facilities available must be checked against the proposed plans. The number of male and female employees and expected patrons using the building at one time will require a fixed number of toilets, urinals, and lavatories, according to the

local, state, and national plumbing codes. The number required will be the determining factor to ensure that the existing building has enough fixtures. The proximity of the public restroom facilities to patron areas (lobby, reading, and conference rooms) and the locations of staff restrooms for employees must be considered. The existing individual fixtures within restrooms must be checked for operation. Many times the seals are broken but can be replaced without replacing the entire fixture. If the fixtures are cracked, they should be replaced. The architect and the consulting engineer must study and analyze all of the plumbing fixtures and water and waste lines and report to the planning team their recommendations.

### C. Barrier-Free Design

Simultaneous with the analysis of the structural, electrical, and mechanical systems of the proposed building or buildings is the development of a barrier-free design. If there are steps to enter the building, locations of ramps need to be planned. Consideration must be given to the width of entrance doors for wheelchairs; to nonslip floor surfaces; to restroom facilities and toilet stalls for handicapped individuals; to the location and height of water fountains, telephones and switches; and to the proper identification of rooms and offices. These are the basic requirements for barrier-free design; additional considerations should be given to other hazards that may pose problems to handicapped persons.

### D. Summary

Repairing and renovating an existing building is one alternative to constructing a new building. Many buildings can be retrofitted and many older buildings have details and charm that newer buildings do not have. If you find a structure of this kind and if the program requirements can be met within the physical structure, then the overall project budget can be reduced and the time to moving day can be shortened. Again, each building must be analyzed and evaluated for structure, utility systems, and adaptability to the functional and architectural program to fulfill the original desires of the administrative agency. See Appendix F for a realistic renovation time schedule.

# Minimum Space and Personnel Required

SPACE	1,000 PATRONS OR LESS			7,000-10,000 PATRONS OR LESS		
	PER-SON-NEL-	SQ. FT.	TOTAL	PER-SON-NEL-	SQ. FT.	TOTAL
ENTRY/						
RECEPTION		200	200	1	800	800
READING		400	400		900	900
CONFERENCE		500	500		1500	1500
OFFICES	2	150/175	300	7	150/175	1225
CLERICAL	2	125	250	5	125	625
COMPUTER		—	—	1	800	800
AUDIO BOOK- PRODUCTION		500	500	4	2800	2800
WORK AREA- SHIPPING/REC.	2	1500	1500	5	3500	3500
MACHINE STORAGE		800	800		1500	1500
MACHINE REPAIR		500	500		750	750
BOOK STACKS		Varies*	Varies*		Varies*	Varies*
Total	6		4950 +	25		14400

## Additional Sq. Footage

Circulation 2.5%—3%

Mech./Janitorial 2%—4%

Lounge/Toilets 3.5%—5%

8%—12% of total space

Note: Minimum space requirements and minimum number of personnel for 1,000 patrons or less are described in Table 3 of *Standards of Service for the Library of Congress Network of Libraries for the Blind and Physically Handicapped*.

\*Book stack square footage must be estimated after calculating linear footage needed to house a current collection plus room for expansion. See Table 4 of *Standards of Service for the Library of Congress Network of Libraries for the Blind and Physically Handicapped*.



# Other Restroom Requirements

STALLS MAY OCCUPY END OF ROOM & BE ENTERED FROM THE SIDE IF DOOR IS 3'-0" WIDE & STALL IS 3'-4" WIDE.

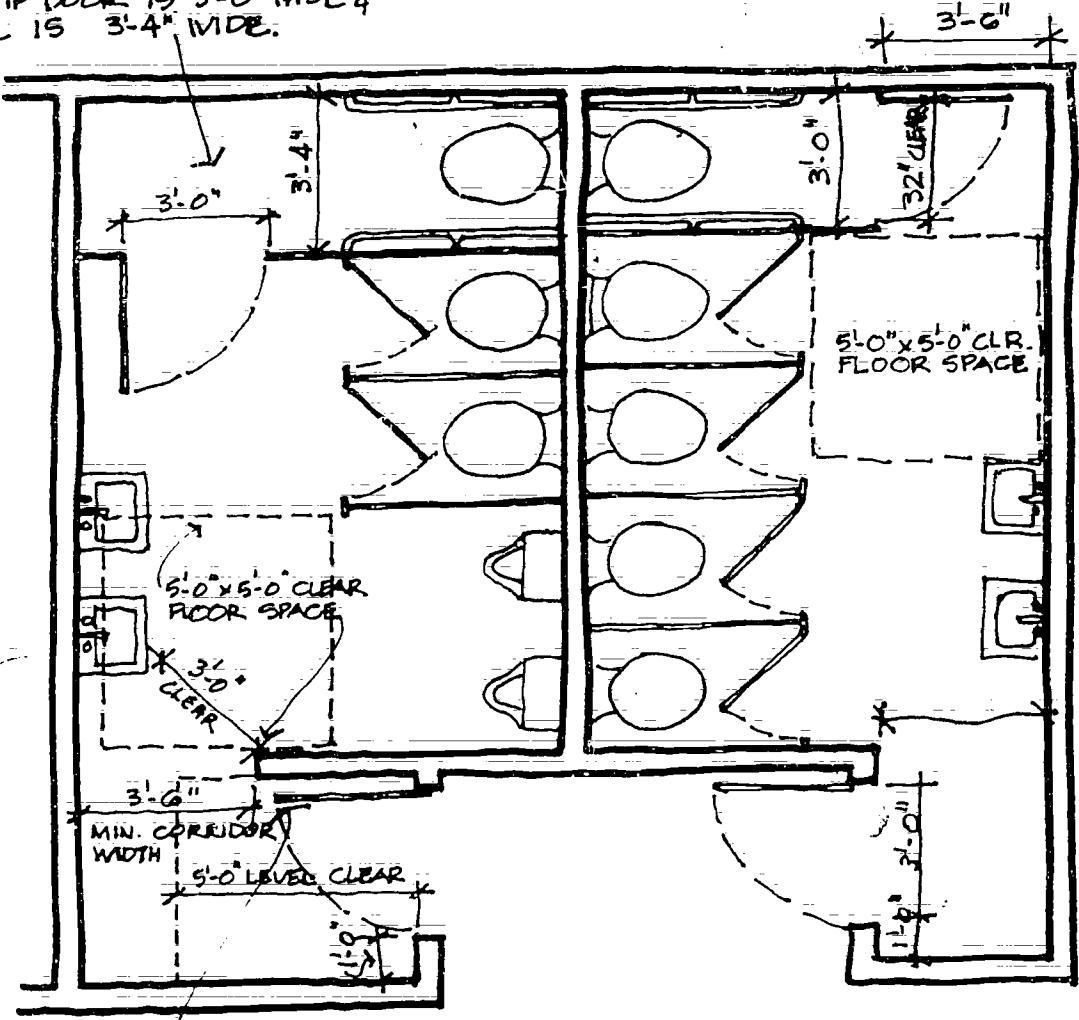

OPEN DOOR MUST NOT OVERLAP 3'-6" MIN. CLEAR CORRIDOR WIDTH

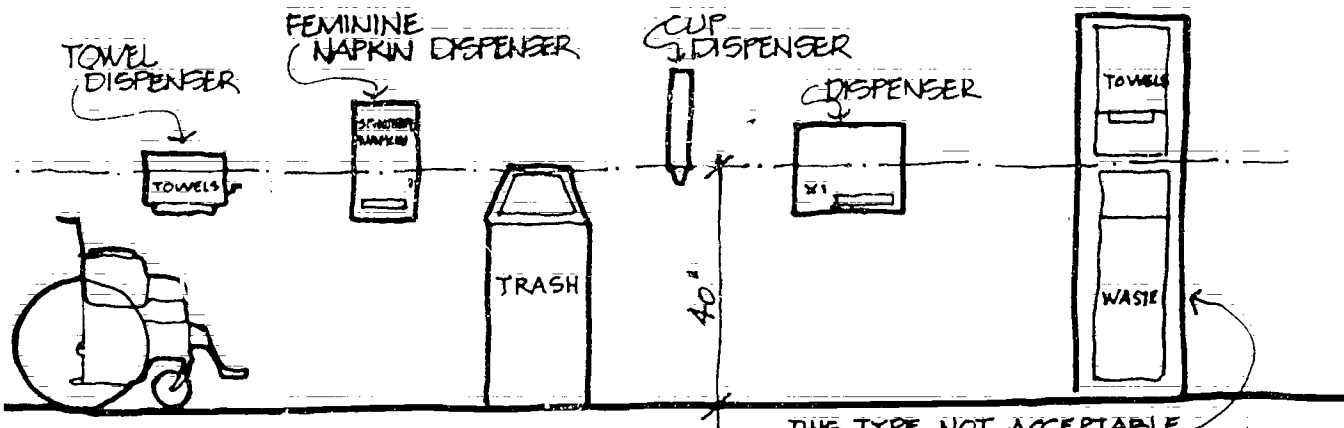
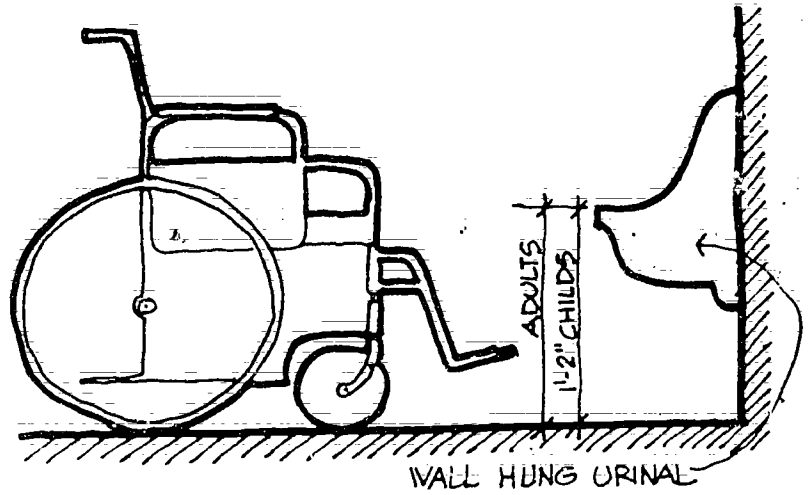

THIS TYPE NOT ACCEPTABLE  
UNLESS SEPARATE TOWEL  
DISPENSER IS ALSO INSTALLED  
AT 40"

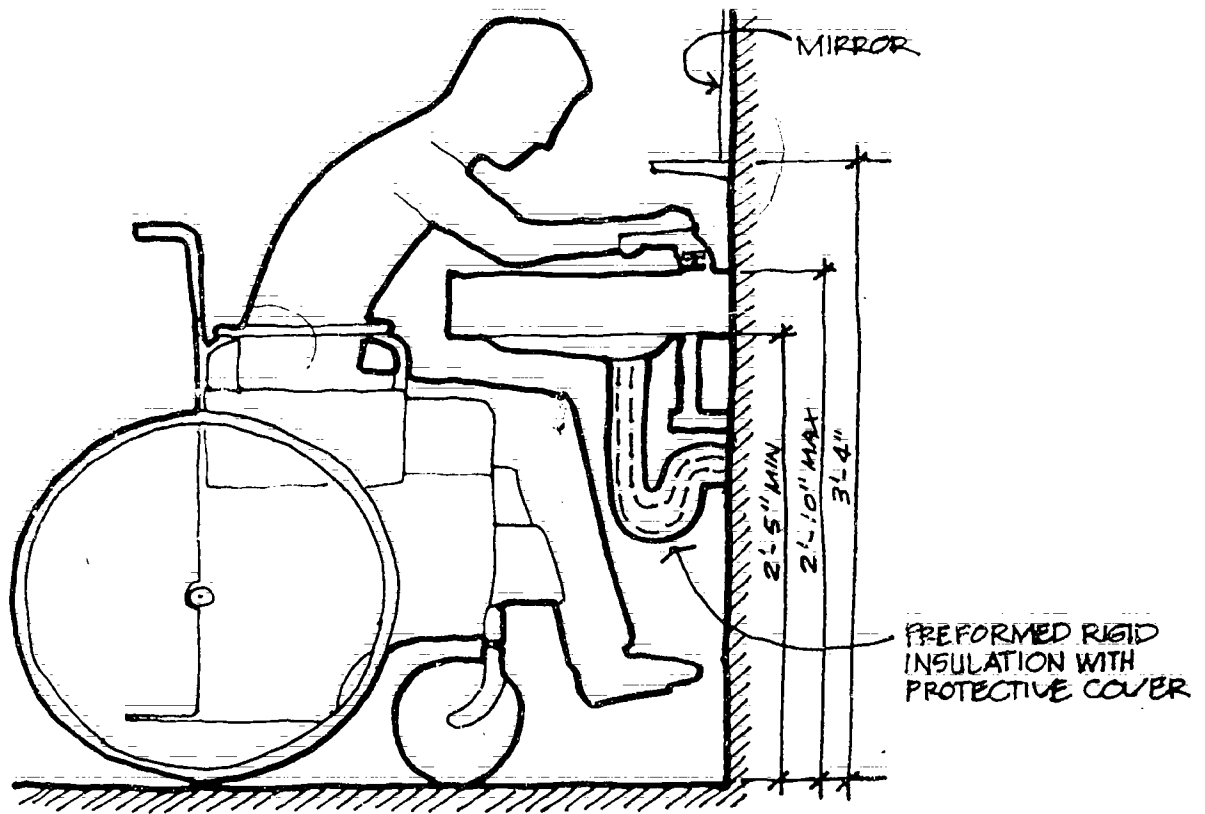

IF HOT WATER EXCEEDS 120°, SUPPLY AND DRAIN LINES MUST BE INSULATED TO PREVENT BURNING PERSONS WITH NO SENSATION IN THEIR LEGS.

ALTERNATE METHOD OF PROTECTION: INCLOSE PLUMBING IN A PROTECTIVE HOUSING. CARE SHOULD BE TAKEN TO PROVIDE ADEQUATE CLEARANCE FOR WHEELCHAIRS.

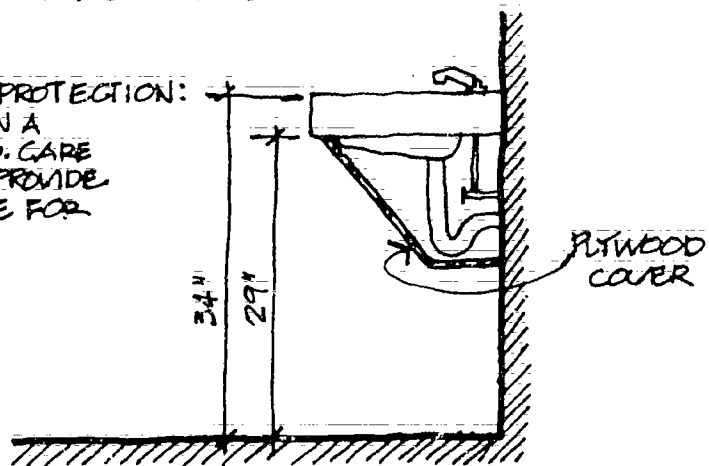

***Flow Diagram***

# Flow Diagram

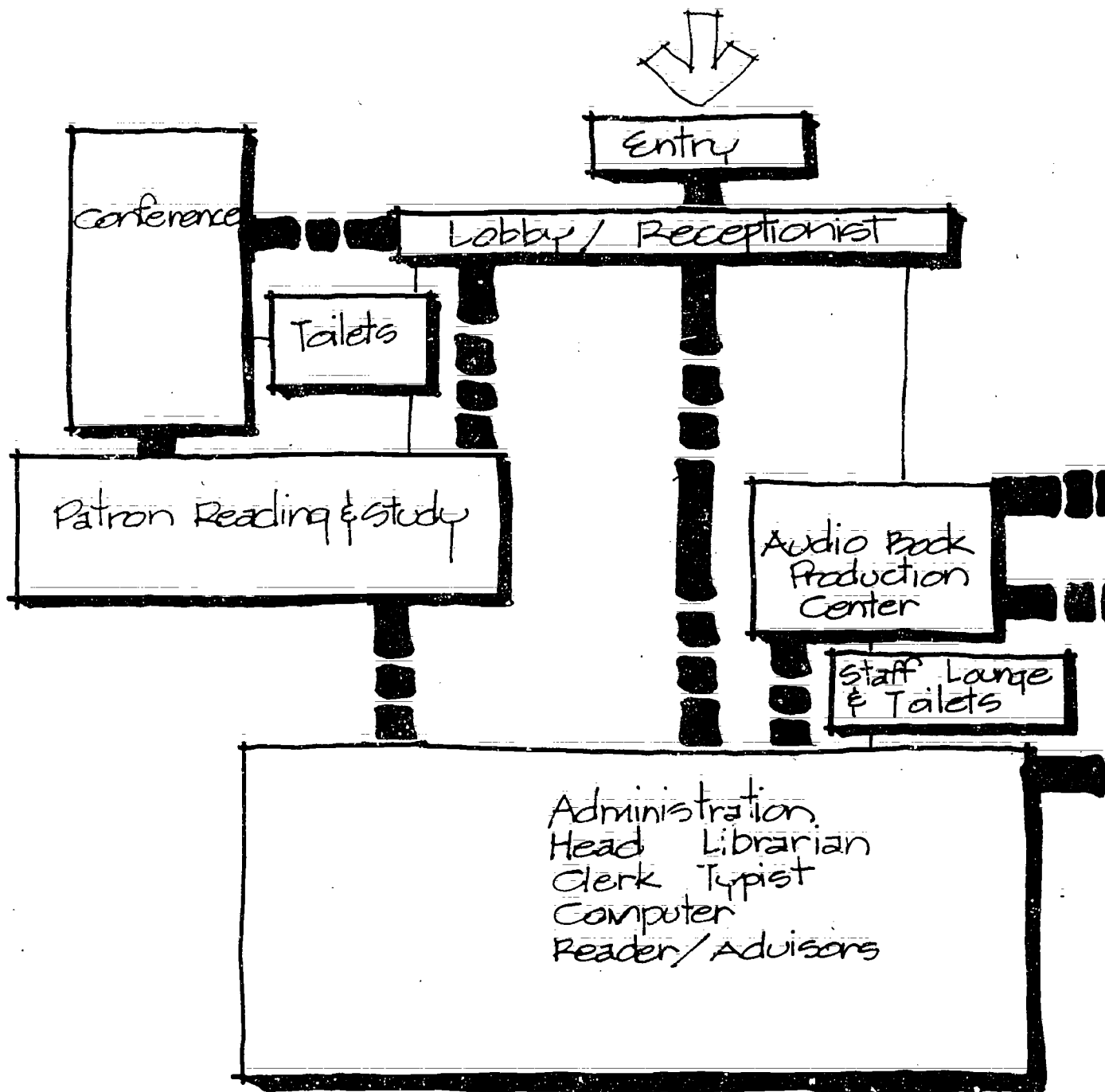

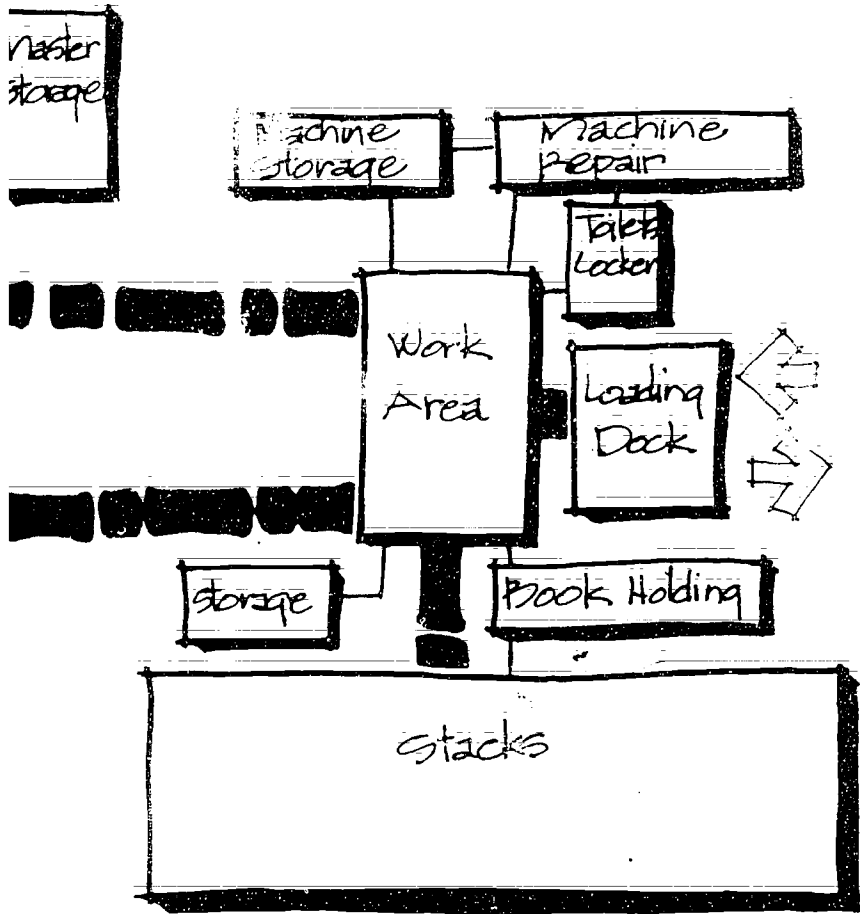

# Suggested Revised Accessibility Checklist\*

## A. Parking Lots

Yes No

1. Are accessible spaces approximate to the facility?
  - a) Are they identified as reserved for use by individuals with physical disabilities?
2. Are there parking spaces open on one side, allowing room (12 feet minimum width) for individuals in wheelchairs or on braces and crutches to get in and out onto a level surface?
  - a) Do they allow people to get in or out on a level surface?
3. Is it unnecessary for individuals in wheelchairs or those using braces and crutches to wheel or walk behind parked cars?
4. Is distribution of spaces for use by the disabled in accordance with the frequency and persistence of parking needs?

_____	_____
_____	_____
_____	_____
_____	_____
_____	_____
_____	_____

### Comments

\*Accessibility—The Law and the Reality: A Survey to Test the Application and Effectiveness of Public Law 90-480 in Iowa. Iowa Chapter, American Institute of Architects, Des Moines, Iowa: 1974. pp. 63-68.

**B. Walks**

- 1. Are public walks at least 48 inches wide? \_\_\_\_\_
- a) Is the gradient not greater than 5 percent? \_\_\_\_\_
- 2. Are walks of a continuing common surface, not interrupted by steps or abrupt changes in level? \_\_\_\_\_
- 3. Wherever they cross other walks, driveways, or parking lots do walks blend to a common level? \_\_\_\_\_
- 4. Do walks have a level platform at the top which is (a) at least 5 feet by 5 feet if a door swings out onto the platform or toward the walk, or (b) 3 feet by 5 feet if the door doesn't swing onto the platform? \_\_\_\_\_
- 5. Does the platform extend at least 1 foot beyond each side of the doorway? \_\_\_\_\_

**Comments**

**C. Ramps**

- 1. Do ramps have a slope no greater than 1 foot rise in 12 feet? \_\_\_\_\_
- 2. Do ramps have handrails on at least one side? \_\_\_\_\_
- a) Are they 32 inches in height measured from the surfaces of the ramp? \_\_\_\_\_
- b) Are the surfaces smooth? \_\_\_\_\_
- c) Do they extend 1 foot beyond the top and bottom of the ramp? \_\_\_\_\_
- 3. Do ramps have a surface that is nonslip? \_\_\_\_\_
- a) Do platforms comply with Questions B4 and B5? \_\_\_\_\_
- 4. Do ramps have at least 6 feet of straight clearance at the bottom? \_\_\_\_\_
- 5. Do ramps have level platforms at 30 foot intervals for purposes of rest and safety, and wherever they turn? \_\_\_\_\_

**Comments**



**D. Entrances/Exits**

- 1. Is at least one primary entrance to each building usable by individuals in wheelchairs? (It is preferable that all or most entrances (exits) be accessible to, and usable by, individuals in wheelchairs or with other forms of physical disability.)
- 2. Is at least one entrance usable by individuals in wheelchairs on a level that would make the elevators accessible?

_____	_____
_____	_____

**Comments**

**E. Doors and Doorways**

- 1. Do doors have a clear opening of no less than 32 inches when open?
  - a) Are they operable by a single effort? Note: Two-leaf doors are not usable by those with disabilities unless they operate by single effort, or unless one of the two leaves meets the 32 inch width.
- 2. Are the doors operable with pressure or strength which could reasonably be expected from disabled persons?
- 3. Is the floor on the inside and outside of each doorway level for a distance of 5 feet from the door in the direction the door swings?
  - a) Does it extend 1 foot beyond each side of door?
- 4. Are sharp inclines and abrupt changes in level avoided at doorsills?
- 5. Do door closers allow the use of doors by physically disabled persons?

_____	_____
_____	_____
_____	_____
_____	_____
_____	_____
_____	_____
_____	_____

**Comments**

**F. Stairs and Steps**

- 1. Do steps avoid abrupt nosing? \_\_\_\_\_
- 2. Do stairs have handrails 32 inches high as measured from the tread at the face of the riser? \_\_\_\_\_
- 3. Do stairs have at least one handrail that extends at least 18 inches beyond the top and bottom step? \_\_\_\_\_
- 4. Do steps have risers 7 inches or less? \_\_\_\_\_

**Comments**

**G. Floors**

- 1. Do floors have a non-slip surface? \_\_\_\_\_
- 2. Are floors on each story at a common level or connected by a ramp? \_\_\_\_\_

**Comments**

**H. Rest Rooms**

- 1. Is there an appropriate number of toilet rooms for each sex?
  - a) Are they accessible to physically handicapped persons? \_\_\_\_\_
  - b) Are they usable by physically handicapped persons? \_\_\_\_\_
- 2. Do toilet rooms have turning space 60 inches x 60 inches to allow traffic of individuals in wheelchairs? \_\_\_\_\_
- 3. Do toilet rooms have at least one toilet stall that:
  - a) is three feet wide? \_\_\_\_\_
  - b) is at least 4 feet 8 inches (preferably 5 feet) deep? \_\_\_\_\_
  - c) has a door that is 32 inches wide and swings out? \_\_\_\_\_
  - d) has grab bars on each side, 33 inches high and parallel to the floor, 1 1/2 inches in diameter, with 1 1/2 inches clearance between rail and wall, fastened securely to the wall at the ends and center? \_\_\_\_\_

- e) has a width of at least 48 inches between the wall and the front of the stall entrance? \_\_\_\_\_
- f) has water closet with seat 20 inches from the floor? \_\_\_\_\_
- 4. Do toilet rooms have lavatories with narrow aprons, which when mounted at standard height are usable by individuals in wheelchairs? \_\_\_\_\_
- 5. Are drain pipes and hot water pipes covered or insulated? \_\_\_\_\_
- 6. Are some mirrors and shelves at a height as low as possible and no higher than 40 inches above the floor? \_\_\_\_\_
- 7. Do toilet rooms for men have wall mounted urinals with the opening of the basin 19 inches from the floor, or have floor mounted urinals that are level with the main floor of the toilet room? \_\_\_\_\_
- 8. Do toilet rooms have towel racks mounted no higher than 40 inches from the floor? \_\_\_\_\_
  - a) Are towel dispensers mounted no higher than 40 inches from the floor? \_\_\_\_\_
  - b) Are other dispensers mounted no higher than 40 inches from the floor? \_\_\_\_\_
  - c) Are disposal units mounted no higher than 40 inches from the floor? \_\_\_\_\_
- 9. Are racks, dispensers and disposal units located to the side of the lavatory rather than directly above? \_\_\_\_\_

**Comments**

**1. Water Fountains**

- 1. Is there an appropriate number of water fountains? \_\_\_\_\_
  - a) Are they accessible to physically handicapped persons? \_\_\_\_\_
  - b) Are they usable by physically handicapped persons? \_\_\_\_\_
- 2. Do water fountains or coolers have up-front spouts and controls? \_\_\_\_\_
- 3. Are they hand operated? \_\_\_\_\_
- 4. Are they hand and foot operated? \_\_\_\_\_

5. If coolers are wall mounted, are they hand operated, with basins 36 inches or less from the floor? \_\_\_\_\_
6. If there are floor mounted fountains, are spouts no higher than 30 inches? \_\_\_\_\_
7. Are these fountains accessible to people in wheelchairs? \_\_\_\_\_

**Comments**

**J. Public Telephones**

1. Is there an appropriate number of public telephones accessible to physically handicapped persons? \_\_\_\_\_
2. Type: booth \_\_\_\_\_ wall mount \_\_\_\_\_
3. Is height of dial from the floor 48 inches or less? \_\_\_\_\_
4. Is coin slot located 48 inches or less from the floor? \_\_\_\_\_
5. (a) Are there telephones equipped for persons with hearing disabilities? \_\_\_\_\_
- (b) Are these telephones identified as such? \_\_\_\_\_

**Comments**

**K. Elevators**

1. If more than a 1 story building, are elevators available to physically handicapped? \_\_\_\_\_
  - a) Are they usable by the physically handicapped? \_\_\_\_\_
2. Are all of the controls 48 inches or less from the floor? \_\_\_\_\_
3. Are the buttons labeled with raised (or indented) letters beside them? \_\_\_\_\_
4. Are they easy to push or touch sensitive? \_\_\_\_\_
5. Is the cab at least 5 feet x 5 feet? \_\_\_\_\_

**Comments**

***L. Controls***

1. Are switches and controls for light, heat, ventilation, windows, draperies, fire alarms, and all similar controls of frequent or essential use, within the reach of individuals in wheelchairs?

\_\_\_\_\_

***Comments***

***M. Identification***

1. Are raised (or recessed) letters or numbers used to identify rooms or offices?
2. Is identification placed on the wall, to the right or left of the door?
  - a) Are they at a height between 4 feet 6 inches and 5 feet 6 inches, measured from the floor?
3. Are doors not intended for normal use, that might prove dangerous if a blind person were to exit or enter by them, made quickly identifiable to the touch by knurling the door handle or knob?

\_\_\_\_\_

\_\_\_\_\_

\_\_\_\_\_

\_\_\_\_\_

***Comments***

***N. Warning Signals***

1. Are audible warning signals accompanied by simultaneous visual signals for the benefit of those with hearing or sight disabilities?

\_\_\_\_\_

***Comments***

*0. Hazards*

1. When manholes or access panels are open and in use, or when an open excavation exists on a site, when it is approximate to normal pedestrian traffic, are barricades placed on all open sides at least 8 feet from the hazard, and warning devices installed? \_\_\_\_\_
2. Are there no low-hanging door closers that remain within the opening of a doorway, or that protrude hazardously into regular corridors or traffic ways? \_\_\_\_\_
3. Are there no low-hanging signs, ceiling lights, fixtures or similar objects that protrude into regular corridors or traffic ways? (A minimum height of 7 feet, measured from the floor, is recommended.) \_\_\_\_\_
4. Is lighting on ramps adequate? \_\_\_\_\_
5. Are exit signs easily identifiable to all disabled persons? \_\_\_\_\_

*Comments*

↙

# Approximate Time Schedule for New Network Library Construction

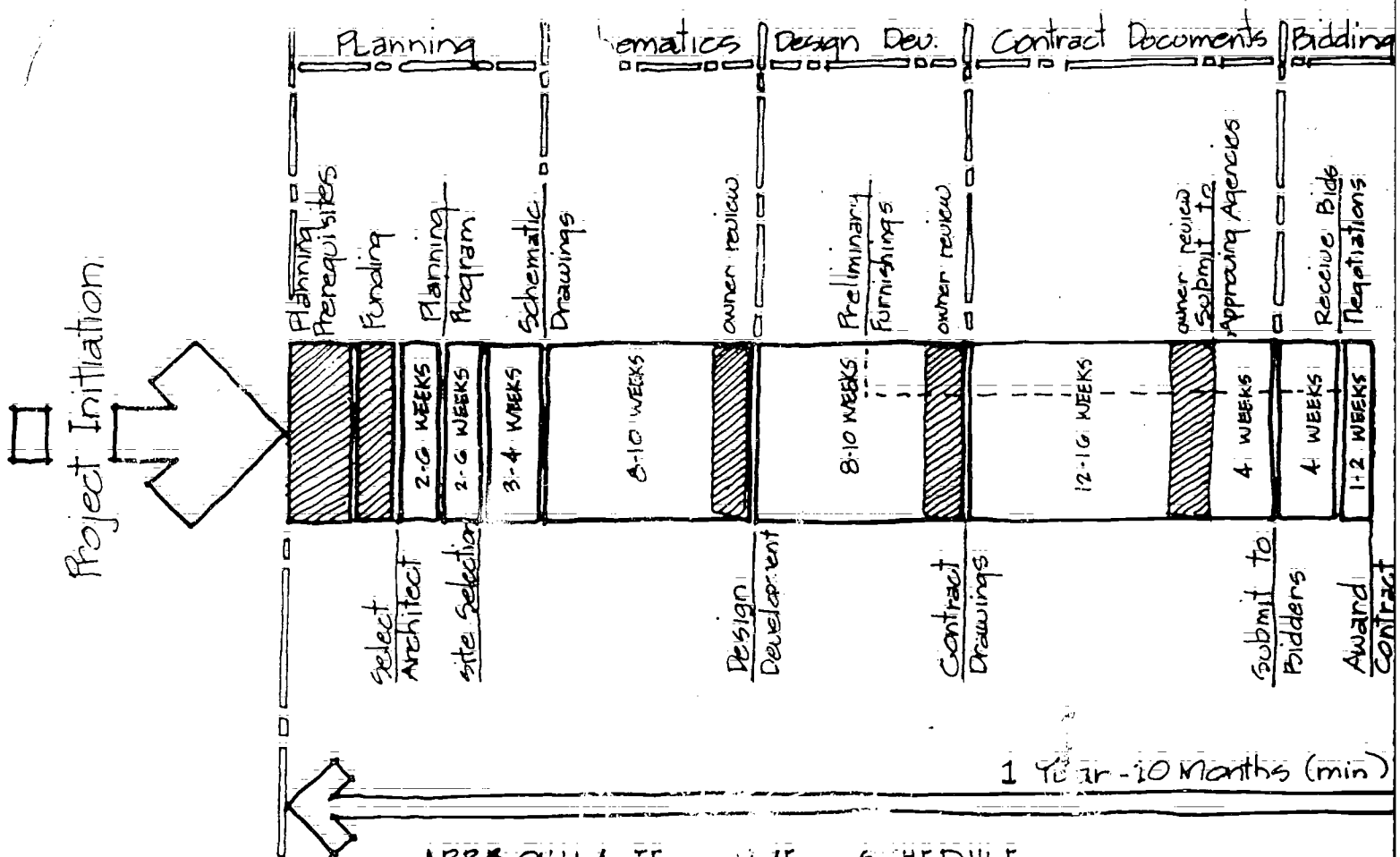

APPROXIMATE TIME SCHEDULE FOR NEW NETWORK LIBRARY CONSTRUCTION SERVING 7,000 TO 10,000 PATRONS

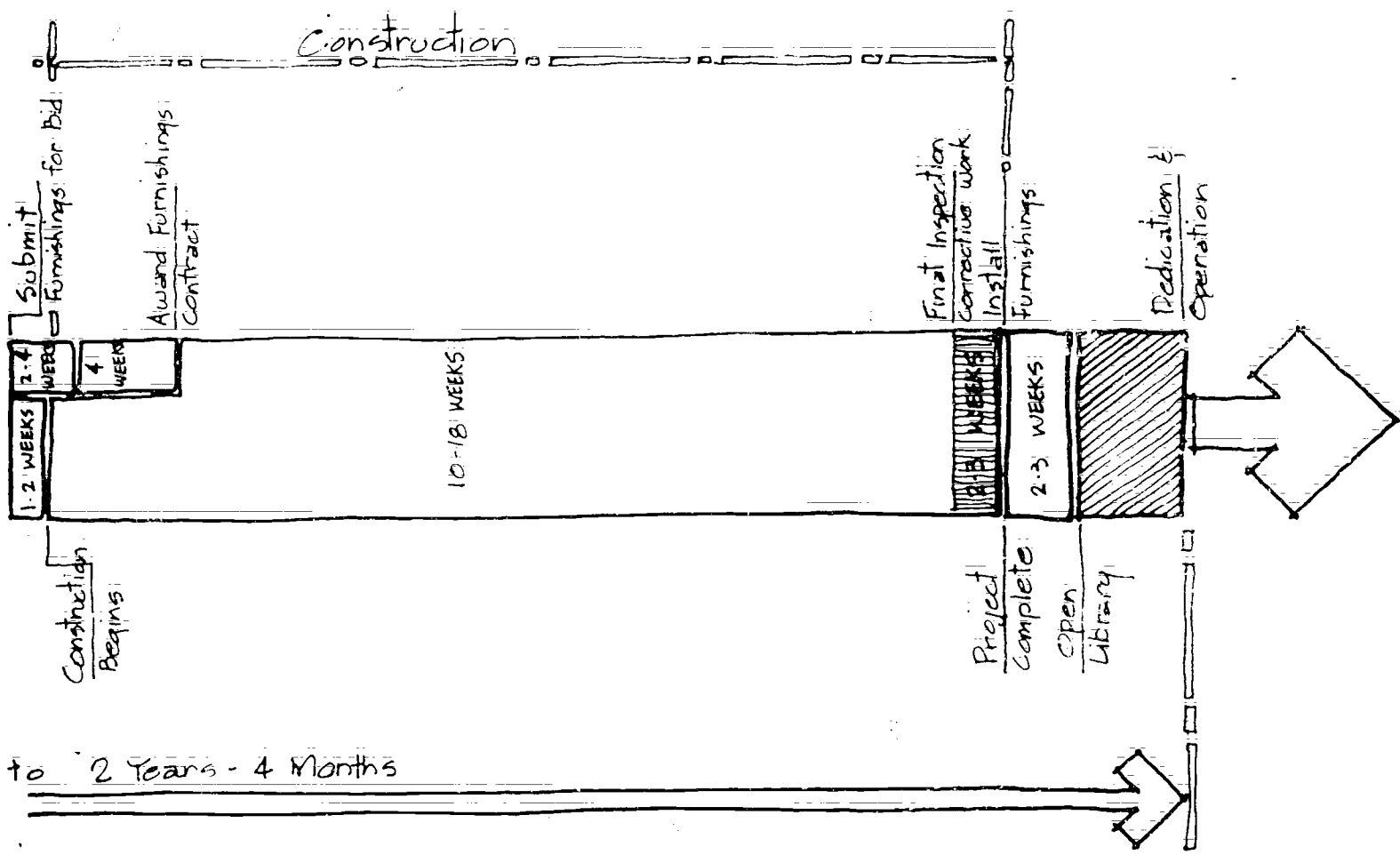



# Approximate Time Schedule for Renovation of Building for Network Library

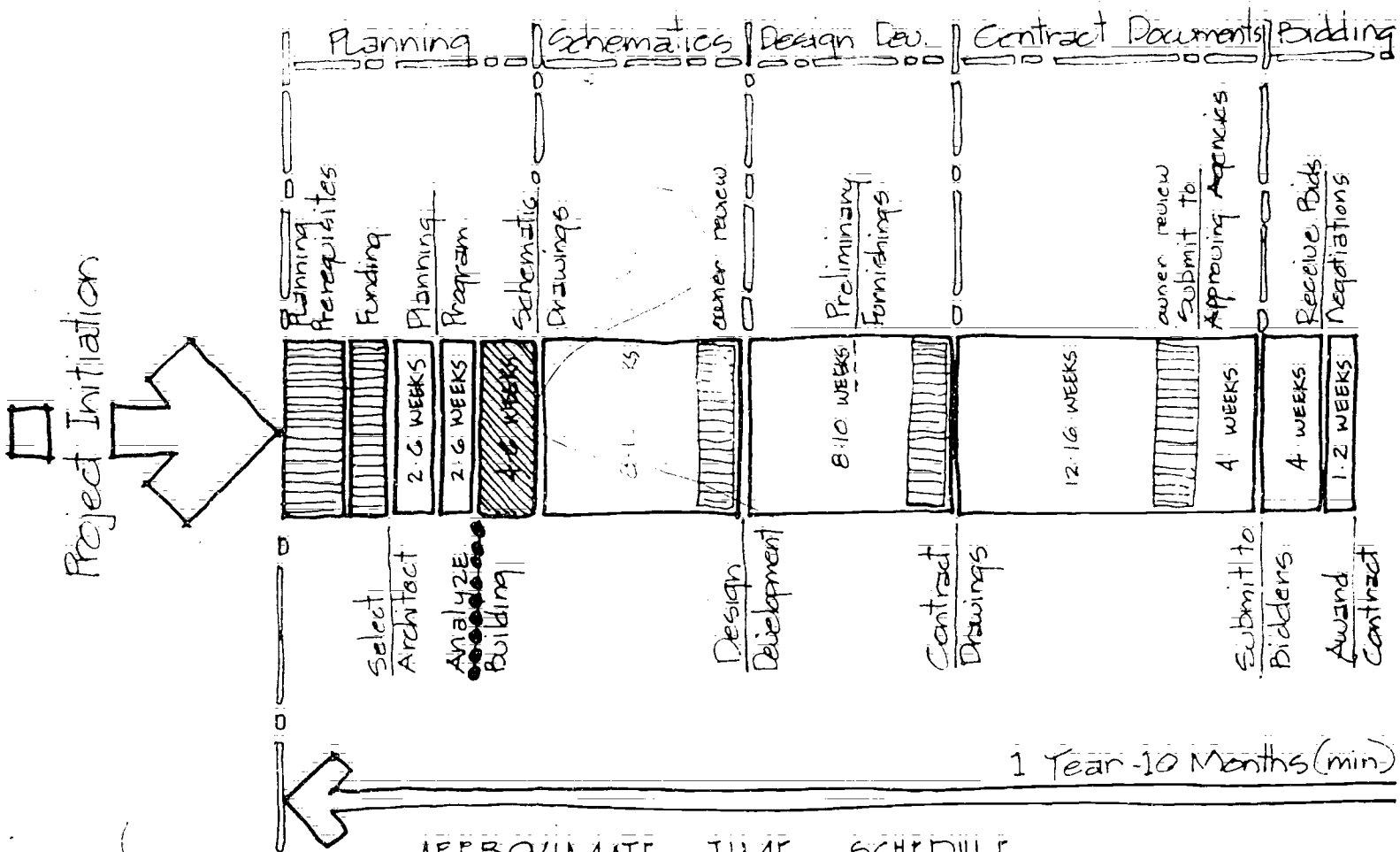

APPROXIMATE TIME SCHEDULE FOR RENOVATION OF BUILDING FOR NETWORK LIBRARY SERVING 7,000 TO 10,000 PATRONS

